

EXAMINED BY :	EMERGING DISPLAY TECHNOLOGIES CORPORATION	FILE NO . CAS-0009553
Lucica Lu		ISSUE : FEB.01, 2024
APPROVED BY:		TOTAL PAGE : 26
Vincent Wn		VERSION : 2

CUSTOMER ACCEPTANCE SPECIFICATIONS

MODEL NO. :
ETML156025LUDYA
 (RoHS)
 FOR MESSRS :

CUSTOMER'S APPROVAL

DATE :

BY :

RECORDS OF REVISION	DOC . FIRST ISSUE	JUL.11, 2023
---------------------	-------------------	--------------

DATE	REVISED PAGE NO.	SUMMARY																																																																
FEB.01, 2024	1	2.1 LCD MODULE MECHANICAL SPECIFICATIONS (13)WEIGHT:TBD→1215g																																																																
	3	<p>3.1 TFT MODULE ELECTRICAL ABSOLUTE MAXIMUM RATINGS</p> <table border="1"> <thead> <tr> <th>ITEM</th> <th>SYMBOL</th> <th>MIN.</th> <th>MAX.</th> <th>UNIT</th> <th>REMARK</th> </tr> </thead> <tbody> <tr> <td>POWER SUPPLY VOLTAGE</td> <td>VDD-VSS</td> <td>(-0.3)</td> <td>(4.0)</td> <td>V</td> <td></td> </tr> <tr> <td>POWER SUPPLY VOLTAGE FOR LED DRIVER</td> <td>VBL+-VSS</td> <td>(-0.3)</td> <td>(27)</td> <td>V</td> <td></td> </tr> </tbody> </table> <p style="text-align: center;">↓</p> <table border="1"> <thead> <tr> <th>ITEM</th> <th>SYMBOL</th> <th>MIN.</th> <th>MAX.</th> <th>UNIT</th> <th>REMARK</th> </tr> </thead> <tbody> <tr> <td>POWER SUPPLY VOLTAGE</td> <td>VDD-VSS</td> <td>-0.3</td> <td>4.0</td> <td>V</td> <td></td> </tr> <tr> <td>POWER SUPPLY VOLTAGE FOR LED DRIVER</td> <td>VBL+-VSS</td> <td>-0.3</td> <td>27</td> <td>V</td> <td></td> </tr> </tbody> </table> <p>3.2 CAPACITIVE TOUCH PANEL ELECTRICAL ABSOLUTE MAXIMUM RATINGS</p> <table border="1"> <thead> <tr> <th>ITEM</th> <th>SYMBOL</th> <th>MIN.</th> <th>MAX.</th> <th>UNIT</th> <th>REMARK</th> </tr> </thead> <tbody> <tr> <td>POWER SUPPLY FOR DRIVER</td> <td>VCC-GND</td> <td>1.25</td> <td>6</td> <td>V</td> <td></td> </tr> </tbody> </table> <p style="text-align: center;">↓</p> <table border="1"> <thead> <tr> <th>ITEM</th> <th>SYMBOL</th> <th>MIN.</th> <th>MAX.</th> <th>UNIT</th> <th>REMARK</th> </tr> </thead> <tbody> <tr> <td>POWER SUPPLY FOR DRIVER</td> <td>VDD1-VSS1</td> <td>1.25</td> <td>6</td> <td>V</td> <td></td> </tr> </tbody> </table> <p>3.3 ENVIRONMENTAL ABSOLUTE MAXIMUM RATINGS NOTE (4) : WHEN THE LCD MODULE IS OPERATED AT AMBIENT TEMPERATURE 80°C, THE PWM DUTY CYCLE OF THE LED BACKLIGHT SHOULD BE ADJUSTED TO BE LESS THAN TBD. IF THE MODULE IS OPERATED AT A HIGHER DUTY CYCLE THAN TBD, THEN THERE IS A POSSIBILITY OF DISTORTION AND IRREGULARITY OF THE PICTURE DUE TO LIQUID CRYSTAL BEHAVIOR.→ WHEN THE LCD MODULE IS OPERATED AT AMBIENT TEMPERATURE 60°C, THE PWM DUTY CYCLE OF THE LED BACKLIGHT SHOULD BE ADJUSTED TO BE LESS THAN 40%. IF THE MODULE IS OPERATED AT A HIGHER DUTY CYCLE THAN 40%, THEN THERE IS A POSSIBILITY OF DISTORTION AND IRREGULARITY OF THE PICTURE DUE TO LIQUID CRYSTAL BEHAVIOR.</p>	ITEM	SYMBOL	MIN.	MAX.	UNIT	REMARK	POWER SUPPLY VOLTAGE	VDD-VSS	(-0.3)	(4.0)	V		POWER SUPPLY VOLTAGE FOR LED DRIVER	VBL+-VSS	(-0.3)	(27)	V		ITEM	SYMBOL	MIN.	MAX.	UNIT	REMARK	POWER SUPPLY VOLTAGE	VDD-VSS	-0.3	4.0	V		POWER SUPPLY VOLTAGE FOR LED DRIVER	VBL+-VSS	-0.3	27	V		ITEM	SYMBOL	MIN.	MAX.	UNIT	REMARK	POWER SUPPLY FOR DRIVER	VCC-GND	1.25	6	V		ITEM	SYMBOL	MIN.	MAX.	UNIT	REMARK	POWER SUPPLY FOR DRIVER	VDD1-VSS1	1.25	6	V					
ITEM	SYMBOL	MIN.	MAX.	UNIT	REMARK																																																													
POWER SUPPLY VOLTAGE	VDD-VSS	(-0.3)	(4.0)	V																																																														
POWER SUPPLY VOLTAGE FOR LED DRIVER	VBL+-VSS	(-0.3)	(27)	V																																																														
ITEM	SYMBOL	MIN.	MAX.	UNIT	REMARK																																																													
POWER SUPPLY VOLTAGE	VDD-VSS	-0.3	4.0	V																																																														
POWER SUPPLY VOLTAGE FOR LED DRIVER	VBL+-VSS	-0.3	27	V																																																														
ITEM	SYMBOL	MIN.	MAX.	UNIT	REMARK																																																													
POWER SUPPLY FOR DRIVER	VCC-GND	1.25	6	V																																																														
ITEM	SYMBOL	MIN.	MAX.	UNIT	REMARK																																																													
POWER SUPPLY FOR DRIVER	VDD1-VSS1	1.25	6	V																																																														
	4	<p>4.1 LCD MODULE ELECTRICAL CHARACTERISTICS</p> <table border="1"> <thead> <tr> <th>ITEM</th> <th>MIN.</th> <th>TYP.</th> <th>MAX.</th> <th>ITEM</th> <th>MIN.</th> <th>TYP.</th> <th>MAX.</th> </tr> </thead> <tbody> <tr> <td>POWER SUPPLY VOLTAGE</td> <td>(3.15)</td> <td>(3.3)</td> <td>(3.45)</td> <td>POWER SUPPLY VOLTAGE</td> <td>3.0</td> <td>3.3</td> <td>3.6</td> </tr> <tr> <td>RUSH CURRENT</td> <td>—</td> <td>—</td> <td>(1.5)</td> <td>RUSH CURRENT</td> <td>—</td> <td>—</td> <td>1.5</td> </tr> <tr> <td>ALLOWABLE LOGIC/LCD DRIVE RIPPLE VOLTAGE</td> <td>—</td> <td>—</td> <td>(200)</td> <td>ALLOWABLE LOGIC/LCD DRIVE RIPPLE VOLTAGE</td> <td>—</td> <td>—</td> <td>200</td> </tr> <tr> <td>POWER SUPPLY CURRENT</td> <td>—</td> <td>—</td> <td>(454)</td> <td>POWER SUPPLY CURRENT</td> <td>—</td> <td>350</td> <td>454</td> </tr> <tr> <td>POWER SUPPLY VOLTAGE FOR LED DRIVER</td> <td>(10.8)</td> <td>(12)</td> <td>(13.2)</td> <td>POWER SUPPLY VOLTAGE FOR LED DRIVER</td> <td>10.8</td> <td>12.0</td> <td>13.2</td> </tr> <tr> <td>POWER SUPPLY CURRENT FOR LED DRIVER</td> <td>—</td> <td>(2)</td> <td>(3)</td> <td>POWER SUPPLY CURRENT FOR LED DRIVER</td> <td>—</td> <td>2</td> <td>2.6</td> </tr> <tr> <td>LED LIFE TIME</td> <td>(50K)</td> <td>—</td> <td>—</td> <td>LED LIFE TIME</td> <td>50K</td> <td>—</td> <td>—</td> </tr> </tbody> </table>	ITEM	MIN.	TYP.	MAX.	ITEM	MIN.	TYP.	MAX.	POWER SUPPLY VOLTAGE	(3.15)	(3.3)	(3.45)	POWER SUPPLY VOLTAGE	3.0	3.3	3.6	RUSH CURRENT	—	—	(1.5)	RUSH CURRENT	—	—	1.5	ALLOWABLE LOGIC/LCD DRIVE RIPPLE VOLTAGE	—	—	(200)	ALLOWABLE LOGIC/LCD DRIVE RIPPLE VOLTAGE	—	—	200	POWER SUPPLY CURRENT	—	—	(454)	POWER SUPPLY CURRENT	—	350	454	POWER SUPPLY VOLTAGE FOR LED DRIVER	(10.8)	(12)	(13.2)	POWER SUPPLY VOLTAGE FOR LED DRIVER	10.8	12.0	13.2	POWER SUPPLY CURRENT FOR LED DRIVER	—	(2)	(3)	POWER SUPPLY CURRENT FOR LED DRIVER	—	2	2.6	LED LIFE TIME	(50K)	—	—	LED LIFE TIME	50K	—	—
ITEM	MIN.	TYP.	MAX.	ITEM	MIN.	TYP.	MAX.																																																											
POWER SUPPLY VOLTAGE	(3.15)	(3.3)	(3.45)	POWER SUPPLY VOLTAGE	3.0	3.3	3.6																																																											
RUSH CURRENT	—	—	(1.5)	RUSH CURRENT	—	—	1.5																																																											
ALLOWABLE LOGIC/LCD DRIVE RIPPLE VOLTAGE	—	—	(200)	ALLOWABLE LOGIC/LCD DRIVE RIPPLE VOLTAGE	—	—	200																																																											
POWER SUPPLY CURRENT	—	—	(454)	POWER SUPPLY CURRENT	—	350	454																																																											
POWER SUPPLY VOLTAGE FOR LED DRIVER	(10.8)	(12)	(13.2)	POWER SUPPLY VOLTAGE FOR LED DRIVER	10.8	12.0	13.2																																																											
POWER SUPPLY CURRENT FOR LED DRIVER	—	(2)	(3)	POWER SUPPLY CURRENT FOR LED DRIVER	—	2	2.6																																																											
LED LIFE TIME	(50K)	—	—	LED LIFE TIME	50K	—	—																																																											
	5	<p>4.2 CAPACITIVE TOUCH PANEL ELECTRICAL CHARACTERISTICS</p> <table border="1"> <thead> <tr> <th>ITEM</th> <th>SYMBOL</th> <th>CONDITION</th> <th>MIN.</th> <th>TYP.</th> <th>MAX.</th> <th>UNIT</th> </tr> </thead> <tbody> <tr> <td>POWER SUPPLY VOLTAGE</td> <td>VCC-GND</td> <td>—</td> <td>4.75</td> <td>5.0</td> <td>5.25</td> <td>V</td> </tr> <tr> <td>POWER SUPPLY CURRENT CONSUMPTION FOR OPERATION</td> <td>ICC</td> <td>VCC-GND =5V</td> <td>—</td> <td>TBD</td> <td>—</td> <td>mA</td> </tr> </tbody> </table> <p style="text-align: center;">↓</p> <table border="1"> <thead> <tr> <th>ITEM</th> <th>SYMBOL</th> <th>CONDITION</th> <th>MIN.</th> <th>TYP.</th> <th>MAX.</th> <th>UNIT</th> </tr> </thead> <tbody> <tr> <td>POWER SUPPLY VOLTAGE</td> <td>VDD1-VSS1</td> <td>—</td> <td>4.75</td> <td>5.0</td> <td>5.25</td> <td>V</td> </tr> <tr> <td>POWER SUPPLY CURRENT CONSUMPTION FOR OPERATION</td> <td>IDD1</td> <td>VDD1-VSS1 =5V</td> <td>—</td> <td>300</td> <td>360</td> <td>mA</td> </tr> </tbody> </table>	ITEM	SYMBOL	CONDITION	MIN.	TYP.	MAX.	UNIT	POWER SUPPLY VOLTAGE	VCC-GND	—	4.75	5.0	5.25	V	POWER SUPPLY CURRENT CONSUMPTION FOR OPERATION	ICC	VCC-GND =5V	—	TBD	—	mA	ITEM	SYMBOL	CONDITION	MIN.	TYP.	MAX.	UNIT	POWER SUPPLY VOLTAGE	VDD1-VSS1	—	4.75	5.0	5.25	V	POWER SUPPLY CURRENT CONSUMPTION FOR OPERATION	IDD1	VDD1-VSS1 =5V	—	300	360	mA																						
ITEM	SYMBOL	CONDITION	MIN.	TYP.	MAX.	UNIT																																																												
POWER SUPPLY VOLTAGE	VCC-GND	—	4.75	5.0	5.25	V																																																												
POWER SUPPLY CURRENT CONSUMPTION FOR OPERATION	ICC	VCC-GND =5V	—	TBD	—	mA																																																												
ITEM	SYMBOL	CONDITION	MIN.	TYP.	MAX.	UNIT																																																												
POWER SUPPLY VOLTAGE	VDD1-VSS1	—	4.75	5.0	5.25	V																																																												
POWER SUPPLY CURRENT CONSUMPTION FOR OPERATION	IDD1	VDD1-VSS1 =5V	—	300	360	mA																																																												

DOC . FIRST ISSUE

RECORDS OF REVISION

JUL.11, 2023

DATE

REVISED
PAGE
NO.

SUMMARY

FEB.01, 2024

9

6.1 OPTICAL CHARACTERISTICS

ITEM	SYMBOL	MIN.	TYP.	MAX.
VIEWING ANGLE	θ_{v-}	(80)	(85)	—
	θ_v	(80)	(85)	—
	θ_{v+}	(80)	(85)	—
	θ_{c-}	(80)	(85)	—
CONTRAST RATIO (CENTER)	CR	(700)	(1000)	—
RESPONSE TIME	TR+TF	—	(25)	(35)
COLOR CHROMATICITY (CENTER)	WHITE	Wx (0.26)	(0.31)	(0.36)
		Wy (0.27)	(0.32)	(0.37)
	RED	Rx (0.59)	(0.64)	(0.69)
		Ry (0.27)	(0.32)	(0.37)
	GREEN	Gx (0.23)	(0.28)	(0.33)
		Gy (0.54)	(0.59)	(0.64)
	BLUE	Bx (0.08)	(0.14)	(0.18)
		By (0.05)	(0.10)	(0.15)
THE BRIGHTNESS OF MODULE (CENTER)	B	(1250)	(1350)	—

ITEM	SYMBOL	MIN.	TYP.	MAX.
VIEWING ANGLE	θ_{v-}	80	85	—
	θ_v	80	85	—
	θ_{v+}	80	85	—
	θ_{c-}	80	85	—
CONTRAST RATIO (CENTER)	CR	700	1000	—
RESPONSE TIME	TR+TF	—	25	35
COLOR CHROMATICITY (CENTER)	WHITE	Wx 0.27	0.32	0.37
		Wy 0.32	0.37	0.42
	RED	Rx 0.59	0.64	0.69
		Ry 0.28	0.33	0.38
	GREEN	Gx 0.25	0.30	0.35
		Gy 0.61	0.66	0.71
	BLUE	Bx 0.09	0.14	0.19
		By 0.05	0.10	0.15
THE BRIGHTNESS OF MODULE (CENTER)	B	1250	1350	—

12

8.2 CTP MODULE

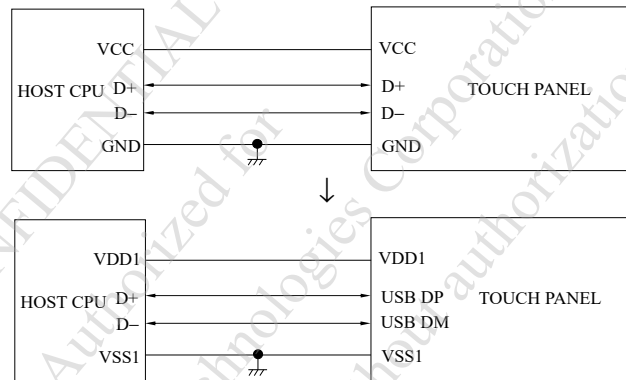

15

10.3 CTP INTERFACE (CN2 USB2.0)→
CTP INTERFACE (CN2 USB2.0 ONLY)

PIN NO.	SYMBOL	DESCRIPTION
1	GND	GROUND
2	VCC	POWER SUPPLY VOLTAGE(+5V)
3	NC	NON CONNECTION
4	NC	NON CONNECTION
5	D+	USB D+
6	D-	USB D-
7	D+	USB D+
8	D-	USB D-
9	NC	NON CONNECTION
10	NC	NON CONNECTION
11	VCC	POWER SUPPLY VOLTAGE(+5V)
12	GND	GROUND

PIN NO.	SYMBOL	FUNCTION
A1	VSS1	GROUND
A2	NC	NON CONNECTION
A3	NC	NON CONNECTION
A4	VDD1	POWER SUPPLY VOLTAGE (+5V)
A5	NC	NON CONNECTION
A6	USB DP	USB D+
A7	USB DM	USB D-
A8	NC	NON CONNECTION
A9	VDD1	POWER SUPPLY VOLTAGE (+5V)
A10	NC	NON CONNECTION
A11	NC	NON CONNECTION
A12	VSS1	GROUND
B1	VSS1	GROUND
B2	NC	NON CONNECTION
B3	NC	NON CONNECTION
B4	VDD1	POWER SUPPLY VOLTAGE (+5V)
B5	NC	NON CONNECTION
B6	USB DP	USB D+
B7	USB DM	USB D-
B8	NC	NON CONNECTION
B9	VDD1	POWER SUPPLY VOLTAGE (+5V)
B10	NC	NON CONNECTION
B11	NC	NON CONNECTION
B12	VSS1	GROUND

RECORDS OF REVISION	DOC . FIRST ISSUE	JUL.11, 2023
---------------------	-------------------	--------------

DATE	REVISED PAGE NO.	SUMMARY																																
FEB.01, 2024	16	<p>11.1 POWER SUPPLY FOR LCM</p>																																
	17	<p>12.1 OPTICAL CHARACTERISTICS</p> <table border="1"> <thead> <tr> <th>ITEM</th> <th>CONDITION</th> <th>MIN.</th> <th>TYP.</th> <th>MAX.</th> <th>UNIT</th> </tr> </thead> <tbody> <tr> <td>TRANSPARENCY NOTE (1)</td> <td>Ta = 25°C λ=550nm</td> <td>(85)</td> <td>—</td> <td>—</td> <td>%</td> </tr> </tbody> </table> <p style="text-align: center;">↓</p> <table border="1"> <thead> <tr> <th>ITEM</th> <th>CONDITION</th> <th>MIN.</th> <th>TYP.</th> <th>MAX.</th> <th>UNIT</th> </tr> </thead> <tbody> <tr> <td>TRANSPARENCY NOTE (1)</td> <td>Ta = 25°C λ=550nm</td> <td>85</td> <td>—</td> <td>—</td> <td>%</td> </tr> </tbody> </table> <p>12.2 HARDNESS</p> <table border="1"> <thead> <tr> <th>ITEM</th> <th>DESCRIPTION</th> <th>ITEM</th> <th>DESCRIPTION</th> </tr> </thead> <tbody> <tr> <td>SURFACE HARDNESS</td> <td>(7H) (min)</td> <td>SURFACE HARDNESS</td> <td>7H (min)</td> </tr> </tbody> </table>	ITEM	CONDITION	MIN.	TYP.	MAX.	UNIT	TRANSPARENCY NOTE (1)	Ta = 25°C λ=550nm	(85)	—	—	%	ITEM	CONDITION	MIN.	TYP.	MAX.	UNIT	TRANSPARENCY NOTE (1)	Ta = 25°C λ=550nm	85	—	—	%	ITEM	DESCRIPTION	ITEM	DESCRIPTION	SURFACE HARDNESS	(7H) (min)	SURFACE HARDNESS	7H (min)
ITEM	CONDITION	MIN.	TYP.	MAX.	UNIT																													
TRANSPARENCY NOTE (1)	Ta = 25°C λ=550nm	(85)	—	—	%																													
ITEM	CONDITION	MIN.	TYP.	MAX.	UNIT																													
TRANSPARENCY NOTE (1)	Ta = 25°C λ=550nm	85	—	—	%																													
ITEM	DESCRIPTION	ITEM	DESCRIPTION																															
SURFACE HARDNESS	(7H) (min)	SURFACE HARDNESS	7H (min)																															

TABLE OF CONTENTS

NO.	ITEM	PAGE
1.	GENERAL SPECIFICATIONS -----	1
2.	MECHANICAL SPECIFICATIONS -----	1, 2
3.	ABSOLUTE MAXIMUM RATINGS -----	3
4.	ELECTRICAL CHARACTERISTICS -----	4, 5
5.	TIMING CHARACTERISTICS -----	6 ~ 8
6.	OPTICAL CHARACTERISTICS -----	9, 10
7.	OUTLINE DIMENSIONS -----	11
8.	BLOCK DIAGRAM -----	12
9.	DETAIL DRAWING OF DOT MATRIX -----	13
10.	INTERFACE SIGNALS -----	14, 15
11.	POWER SUPPLY -----	16
12.	CAPACITIVE TOUCH PANEL SPECIFICATION -----	17
13.	INSPECTION CRITERIA -----	18~ 23
14.	RELIABILITY TEST -----	24
15.	CAUTION -----	25, 26

CONFIDENTIAL
 Authorized for Emerging Display Technologies Corporation Only.
 Do not distribute without authorization.

1. GENERAL SPECIFICATIONS

1.1 DATA SHEETS FOR TFT MODULE CONTROLLER/DRIVER
PLEASE REFER TO :

HX-8255B

1.2 APPLICATION NOTES FOR CAPACITIVE TOUCH PANEL CONTROLLER/DRIVER
PLEASE REFER TO :

TOUCHNETIX AX112A

1.3 MATERIAL SAFETY DESCRIPTION

ASSEMBLIES SHALL COMPLY WITH EUROPEAN ROHS REQUIREMENTS, INCLUDING PROHIBITED MATERIALS/COMPONENTS CONTAINING LEAD, MERCURY, CADMIUM, HEXAVALENT CHROMIUM, POLYBROMINATED BIPHENYLS (PBB) AND POLYBROMINATED DIPHENYL ETHERS (PBDE), BIS(2-ETHYLHEXYL) PHTHALATE (DEHP), BUTYL BENZYL PHTHALATE (BBP), DIBUTYL PHTHALATE (DBP), DIISOBUTYL PHTHALATE (DIBP).

2. MECHANICAL SPECIFICATIONS

2.1 LCD MODULE MECHANICAL SPECIFICATIONS

- (1) DIAGONALS ----- 15.6 inch
- (2) NUMBER OF DOTS ----- 1920W(RGB) * 1080H DOTS
- (3) MODULE SIZE ----- 363.8W * 215.9H * 17.5D(MAX.) mm
(WITHOUT FPC)
- (4) VIEWING AREA ----- 374.16W * 196.59H mm
- (5) ACTIVE AREA ----- 344.16W * 193.59H mm
- (6) DOT SIZE ----- 0.05975W * 0.17925H mm
- (7) PIXEL SIZE ----- 0.17925W * 0.17925H mm
- (8) LCD TYPE ----- TFT, IPS, TRANSMISSIVE,
NORMALLY BLACK
- (9) COLOR ----- 16.7M
- (10) VIEWING DIRECTION ----- SUPER WIDE VIEW
- (11) BACK LIGHT ----- LED , COLOR : WHITE
- (12) INTERFACE MODE ----- LVDS
- (13) WEIGHT ----- 1215g

2.2 CAPACITIVE TOUCH PANEL MECHANICAL SPECIFICATIONS

- (1) TOUCH PANEL SIZE ----- 15.6 inch
- (2) OUTER DIMENSION ----- 361.8W * 213.9H * 2.4D mm
(WITHOUT FPC)
- (3) ACTIVE AREA ----- 346.16W * 195.59H mm
- (4) INPUT TYPE ----- MULTI-TOUCH
- (5) NUMBER OF TOUCH SENSOR ----- 48*27 SENSORS
- (6) RESOLUTION ----- 1920*1080
- (7) INTERFACE MODE ----- USB 2.0

CONFIDENTIAL
Authorized for
Emerging Display Technologies Corporation Only.
Do not distribute without authorization.

3. ABSOLUTE MAXIMUM RATINGS

3.1 TFT MODULE ELECTRICAL ABSOLUTE MAXIMUM RATINGS

ITEM	SYMBOL	MIN.	MAX.	UNIT	REMARK
POWER SUPPLY VOLTAGE	VDD-VSS	-0.3	4.0	V	
POWER SUPPLY VOLTAGE FOR LED DRIVER	VBL+-VSS	-0.3	27	V	

3.2 CAPACITIVE TOUCH PANEL ELECTRICAL ABSOLUTE MAXIMUM RATINGS

ITEM	SYMBOL	MIN.	MAX.	UNIT	REMARK
POWER SUPPLY FOR DRIVER	VDD1-VSS1	1.25	6	V	

3.3 ENVIRONMENTAL ABSOLUTE MAXIMUM RATINGS

ITEM	OPERATING		STORAGE		REMARK
	MIN.	MAX.	MIN.	MAX.	
AMBIENT TEMPERATURE	-30°C	85°C	-30°C	85°C	NOTE (1), (2), (3), (4)
HUMIDITY	NOTE (3)		NOTE (3)		WITHOUT CONDENSATION
VIBRATION	—	2.45 m/s ² (0.25 G)	—	11.76m/s ² (1.2 G)	10~100 Hz XYZ DIRECTIONS 1 HR EACH
SHOCK	—	29.4 m/s ² (3 G)	—	490.0 m/s ² (50 G)	10 ms XYZ DIRECTIONS 1 TIME EACH
CORROSIVE GAS	NOT ACCEPTABLE		NOT ACCEPTABLE		

NOTE (1) : THE ABSOLUTE MAXIMUM RATINGS OF THIS PRODUCT SHOULD NOT BE EXCEEDED AT ANY TIME. IF THESE RATINGS ARE EXCEEDED, THE PRODUCT'S PERFORMANCE IS NOT GUARANTEED AND THE PRODUCT MAY EXPERIENCE PERMANENT DAMAGE.

NOTE (2) : BACKGROUND COLOR CHANGES SLIGHTLY DEPENDING ON AMBIENT TEMPERATURE THIS PHENOMENON IS REVERSIBLE.

NOTE (3) : Ta ≤ 40°C : 90%RH MAX. (96HRS MAX).

Ta > 40°C : ABSOLUTE HUMIDITY MUST BE LOWER THAN THE HUMIDITY OF 90%RH AT 40°C (96HRS MAX).

NOTE (4) : WHEN THE LCD MODULE IS OPERATED AT AMBIENT TEMPERATURE 60°C, THE PWM DUTY CYCLE OF THE LED BACKLIGHT SHOULD BE ADJUSTED TO BE LESS THAN 40%. IF THE MODULE IS OPERATED AT A HIGHER DUTY CYCLE THAN 40%, THEN THERE IS A POSSIBILITY OF DISTORTION AND IRREGULARITY OF THE PICTURE DUE TO LIQUID CRYSTAL BEHAVIOR.

4. ELECTRICAL CHARACTERISTICS

4.1 LCD MODULE ELECTRICAL CHARACTERISTICS

Ta = 25 °C

ITEM	SYMBOL	CONDITION	MIN.	TYP.	MAX.	UNIT	REMARK
POWER SUPPLY VOLTAGE	VDD-VSS	—	3.0	3.3	3.6	V	
RUSH CURRENT	I _{Rush}	—	—	—	1.5	A	NOTE (4)
ALLOWABLE LOGIC/LCD DRIVE RIPPLE VOLTAGE	V _{VDD-RP}	—	—	—	200	mV	NOTE (3)
POWER SUPPLY CURRENT	IDD	VDD-VSS = 3.3V	—	350	454	mA	NOTE (1)
POWER SUPPLY VOLTAGE FOR LED DRIVER	VBL+-VBL-	—	10.8	12.0	13.2	V	NOTE (2)
POWER SUPPLY VOLTAGE FOR LED DRIVER	BL_PWM	V _{IH}	1.6	—	—	V	
		V _{IL}	—	—	0.8	V	
	BL_EN	V _{IH}	1.6	—	—	V	
		V _{IL}	—	—	0.8	V	
POWER SUPPLY CURRENT FOR LED DRIVER	IBL+	VBL+-VBL- = 12V LED B/L=ON PWM=100%	—	2	2.6	A	
LED LIFE TIME	—	IF=60mA (PER LED)	50K	—	—	HRS	NOTE (5) NOTE (6)

NOTE (1) : THE DISPLAY PATTERN IS ALL “WHITE”.

NOTE (2) : INTERNAL CIRCUIT DIAGRAM OF BACKLIGHT

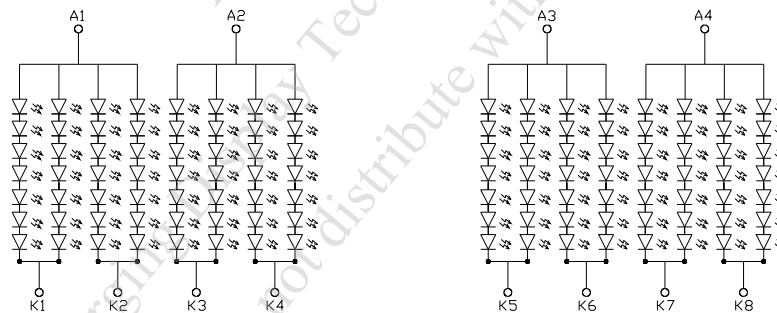

NOTE (3) : THE SPECIFIED V_{CC} CURRENT AND POWER CONSUMPTION ARE MEASURED UNDER THE V_{DD} = 3.3 V, F_V = 60 Hz CONDITION AND WHITE PATTERN.

NOTE (4) : THE FIGURES BELOW IS THE MEASURING CONDITION OF V_{DD}. RUSH CURRENT CAN BE MEASURED WHEN T_{RUSH} IS 0.5 ms.

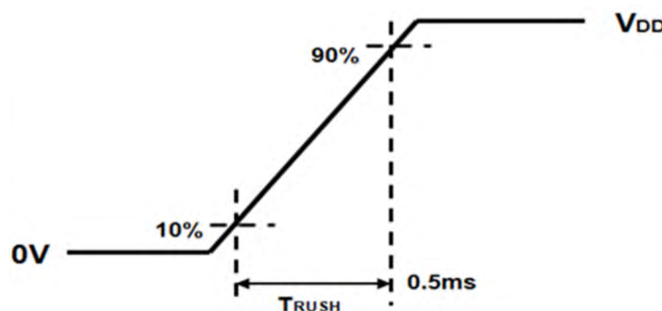

NOTE (5) : CONDITIONS; Ta=25 °C, CONTINUOUS LIGHTING

NOTE (6) : DEFINITIONS OF LIFE TIME :

4.2 CAPACITIVE TOUCH PANEL ELECTRICAL CHARACTERISTICS

Ta = 25°C

ITEM	SYMBOL	CONDITION	MIN.	TYP.	MAX.	UNIT
POWER SUPPLY VOLTAGE	VDD1-VSS1	—	4.75	5.0	5.25	V
POWER SUPPLY CURRENT CONSUMPTION FOR OPERATION	IDD1	VDD1-VSS1 =5V	—	300	360	mA

CONFIDENTIAL
Authorized for
Emerging Display Technologies Corporation Only.
Do not distribute without authorization.

5. TIMING CHARACTERISTICS

5.1 SIGNAL ELECTRICAL CHARACTERISTICS

5.1.1 SIGNAL ELECTRICAL CHARACTERISTICS FOR LVDS RECEIVER
THE BUILT-IN LVDS RECEIVER IS COMPATIBLE WITH (ANSI/TIA/TIA-644)
STANDARD.

LVDS RECEIVER ELECTRICAL CHARACTERISTICS

ITEM	SYMBOL	MIN.	TYP.	MAX.	UNIT	CONDITIONS
DIFFERENTIAL INPUT HIGH THRESHOLD	V_{th}	—	—	(+100)	mV	$V_{CM} = 1.2V$
DIFFERENTIAL INPUT LOW THRESHOLD	V_{tl}	(-100)	—	—	mV	$V_{CM} = 1.2V$
MAGNITUDE DIFFERENTIAL INPUT VOLTAGE	$ V_{ID} $	(150)	—	(600)	mV	
COMMON MODE VOLTAGE	V_{CM}	(0.7)	—	(1.6)	V	

NOTE (1) : INPUT SIGNALS SHALL BE LOW OR HI- RESISTANCE STATE WHEN VDD IS OFF.

NOTE (2) : ALL ELECTRICAL CHARACTERISTICS FOR LVDS SIGNAL ARE DEFINED AND SHALL BE MEASURED AT THE INTERFACE CONNECTOR OF LCD.

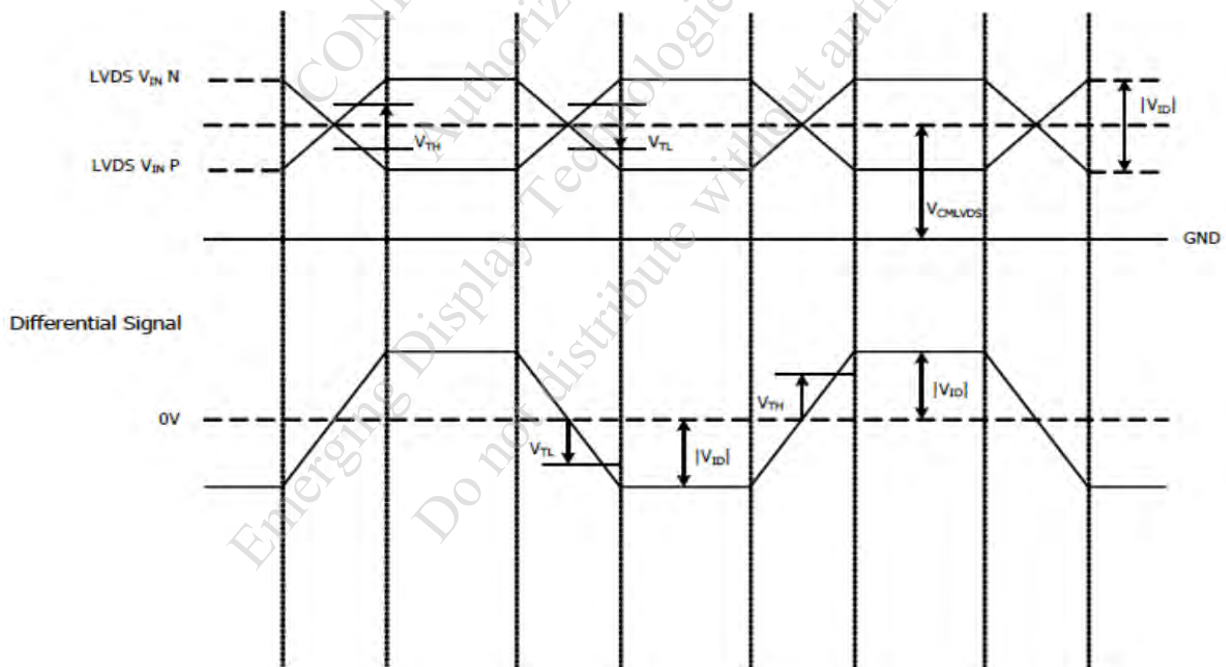

VOLTAGE DEFINITIONS

LVDS AC ELECTRICAL CHARACTERISTICS

ITEM	SYMBOL	MIN.	TYP.	MAX.	UNIT	CONDITIONS
CLOCK PERIOD	TLVCP	—	(T)	—	ns	
CLOCK HIGH TIME	TLVCH	—	(4T/7)	—	ns	
CLOCK LOW TIME	TLVCL	—	(3T/7)	—	ns	

NOTE : $T=1/F_{clk}$

5.1.2 LVDS INTERFACE DATA MAPPING

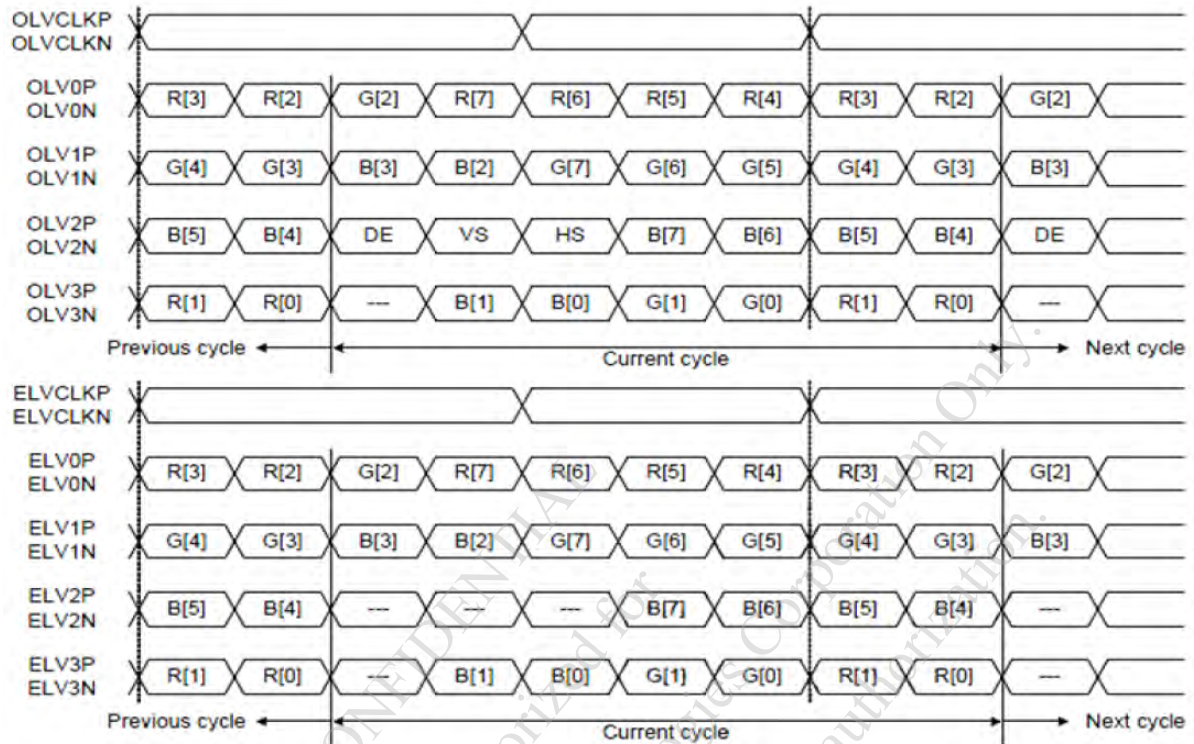

DATA MAPPING

5.2 LVDS RECEIVER INTERNAL CIRCUIT

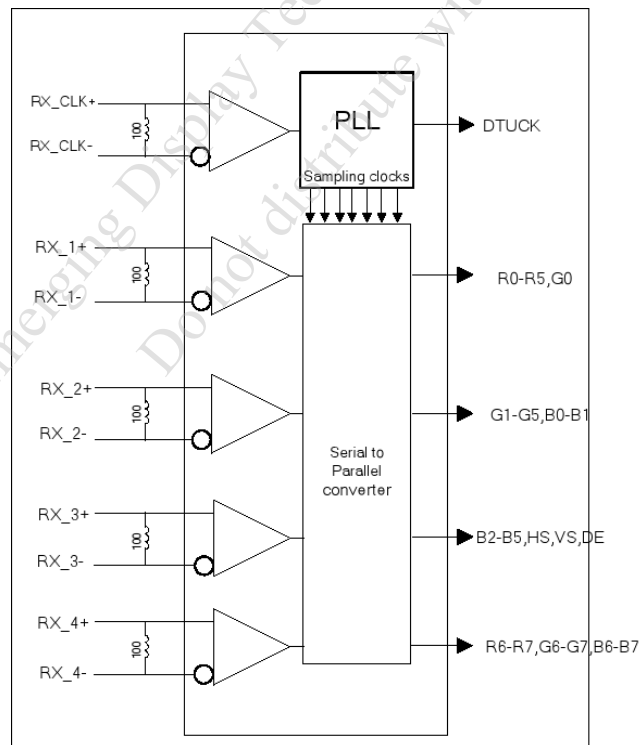

LVDS RECEIVER INTERNAL CIRCUIT

5.3 LVDS INTERFACE TIMING

ITEM	SYMBOL	MIN.	TYP.	MAX.	UNIT	REMARK
LVDS CLOCK FREQUENCY	Fclk	(69.5)	(70.5)	(73)	Mhz	
V TOTAL TIME	VT	(1104)	(1116)	(1080+A)	Clocks	
V ACTIVE TIME	VA	1080			—	
H TOTAL TIME	HT	(1050)	(1052)	(1920+B)	Lines	
H ACTIVE TIME	HA	1920			—	
FRAME RATE	FV	—	(60)	—	Hz	

NOTE (1) : SSC CAN ONLY BE DRIVEN TO 2%

NOTE (2) : THE MAXIMUM CLOCK FREQUENCY= $[(1920+B)*(1080+A)*60]<73\text{MHz}$

5.4 POWER SEQUENCE

INTERFACE SIGNALS ARE ALSO SHOWN IN THE CHART. SIGNALS FROM ANY SYSTEM SHALL BE HI- RESISTANCE STATE OR LOW LEVEL WHEN VDD VOLTAGE IS OFF.

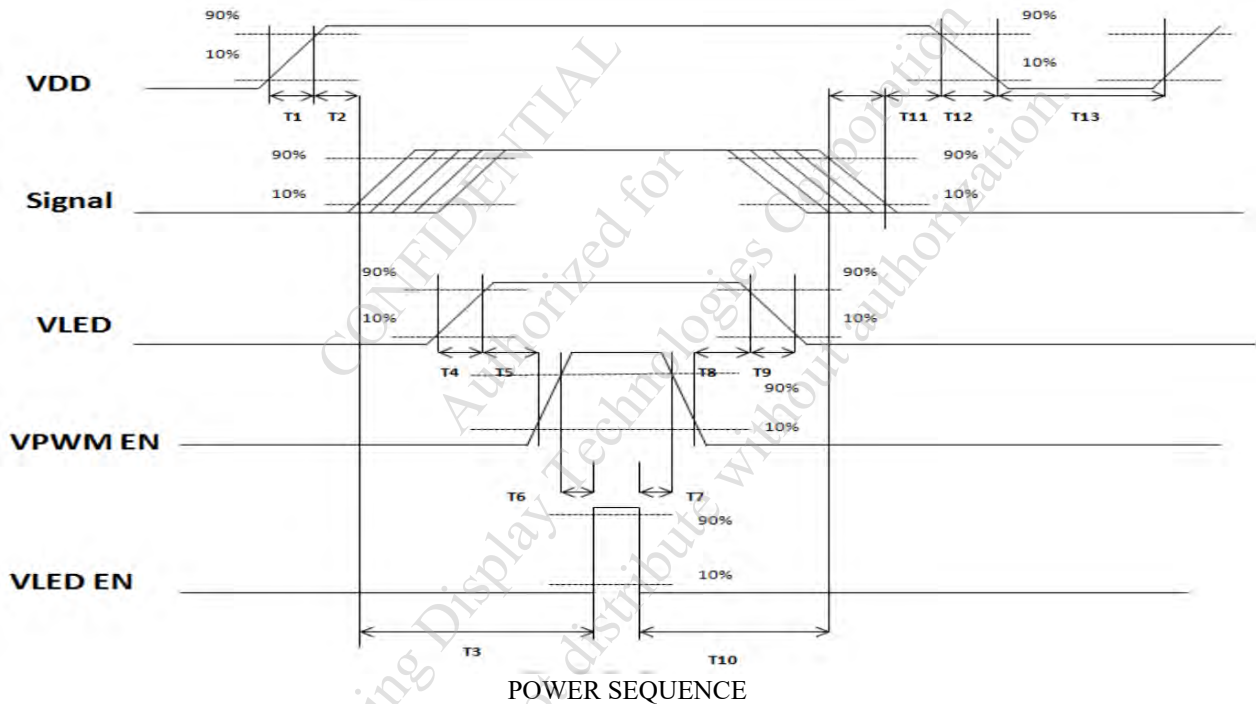

POWER SEQUENCING REQUIREMENTS

ITEM	MIN.	TYP.	MAX.	UNIT	REMARK
T1	(0.5)	—	(10)	ms	
T2	(30)	(40)	(50)	ms	
T3	(200)	—	—	ms	
T4	(0.5)	—	(10)	ms	
T5	(10)	—	—	ms	
T6	(10)	—	—	ms	
T7	(0)	—	—	ms	
T8	(10)	—	—	ms	
T9	—	—	(10)	ms	
T10	(110)	—	—	ms	
T11	(0)	(16)	(50)	ms	
T12	—	—	(10)	ms	
T13	(1000)	—	—	ms	

6. OPTICAL CHARACTERISTICS

6.1 OPTICAL CHARACTERISTICS

Ta = 25 ± 2 °C

ITEM	SYMBOL	CONDITION	MIN.	TYP.	MAX.	UNIT	REMARK	
VIEWING ANGLE	θ_{y+}	CR ≥ 10	$\theta_x=0^\circ$	80	85	—	deg	NOTE (2) NOTE (3)
	θ_{y-}			80	85	—	deg	
	θ_{x+}		$\theta_y=0^\circ$	80	85	—	deg	
	θ_{x-}			80	85	—	deg	
CONTRAST RATIO (CENTER)	CR	$\theta_x=0^\circ, \theta_y=0^\circ$	700	1000	—	—	NOTE (3)	
RESPONSE TIME	TR+TF	$\theta_x=0^\circ, \theta_y=0^\circ$	—	25	35	msec	NOTE (4)	
COLOR CHROMATICITY (CENTER)	WHITE	Wx	$\theta_x=0^\circ, \theta_y=0^\circ$ VDD-VSS=3.3V VBL+ -VBL- =12V LED B/L=ON PWM=100%	0.27	0.32	0.37	—	NOTE (5)
		Wy		0.32	0.37	0.42		
	RED	Rx		0.59	0.64	0.69	—	
		Ry		0.28	0.33	0.38		
	GREEN	Gx		0.25	0.30	0.35	—	
		Gy		0.61	0.66	0.71		
	BLUE	Bx		0.09	0.14	0.19	—	
		By		0.05	0.10	0.15		
THE BRIGHTNESS OF MODULE (CENTER)	B		1250	1350	—	cd/m ²	NOTE (6)	
THE UNIFORMITY OF MODULE	—		70	—	—	%	NOTE (7)	

NOTE (1) : TEST CONDITION :

AFTER STABILIZING AND LEAVING THE PANEL ALONE AT A GIVEN TEMPERATURE FOR 30 MINUTES. MEASUREMENT SHOULD BE EXECUTED IN A STABLE, WINDLESS, AND DARK ROOM.

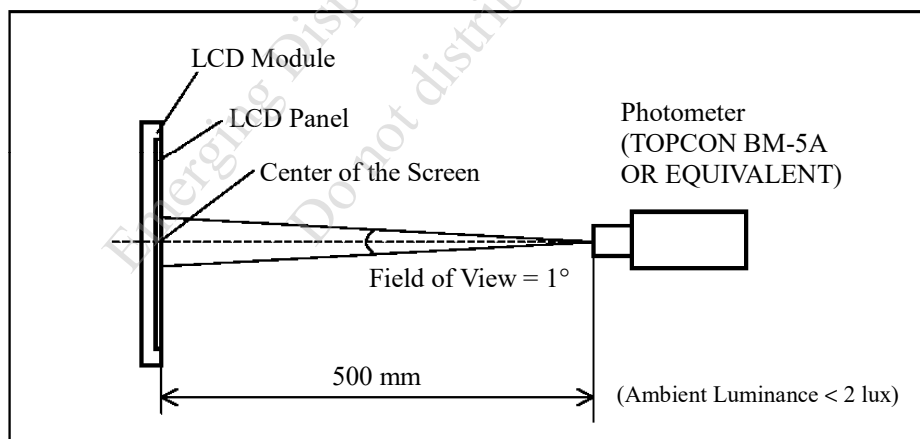

NOTE (2) : DEFINITION OF VIEWING ANGLE :

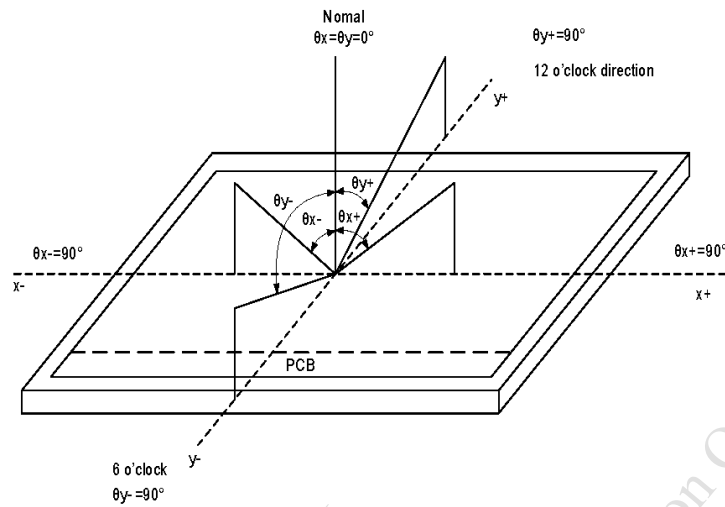

NOTE (3) : DEFINITION OF CONTRAST RATIO (CR) :

MEASURED AT THE CENTER POINT OF MODULE

$$\text{CONTRAST RATIO(CR)} = \frac{\text{BRIGHTNESS MEASURED WHEN LCD IS AT "WHITE STATE"}}{\text{BRIGHTNESS MEASURED WHEN LCD IS AT "BLACK STATE"}}$$

NOTE (4) : DEFINITION OF RESPONSE TIME : T_R AND T_F

THE FIGURE BELOW IS THE OUTPUT SIGNAL OF THE PHOTO DETECTOR.

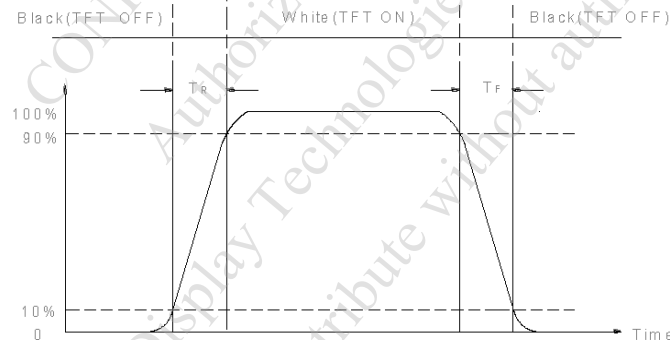

NOTE (5) : DEFINITION OF COLOR CHROMATICITY

(a) 100% RGB PIXEL DATA TRANSMISSION WHEN ALL THE INPUT TERMINALS OF MODULE ARE ELECTRICALLY POWERED ON.

(b) MEASURED AT THE CENTER POINT OF MODULE

NOTE (6) : MEASURED THE BRIGHTNESS OF WHITE STATE AT CENTER POINT.

NOTE (7) : (a) DEFINITION OF BRIGHTNESS UNIFORMITY

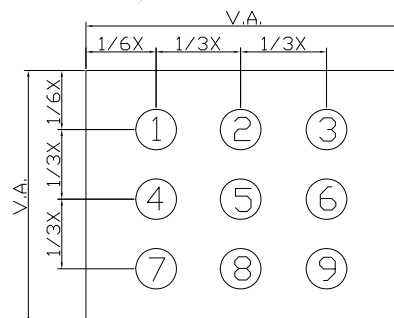

UNIT : mm

(b) THE BRIGHTNESS UNIFORMITY CALCULATING METHOD

$$\text{UNIFORMITY} : \frac{\text{MINIMUM BRIGHTNESS}}{\text{MAXIMUM BRIGHTNESS}} * 100\%$$

7. OUTLINE DIMENSIONS

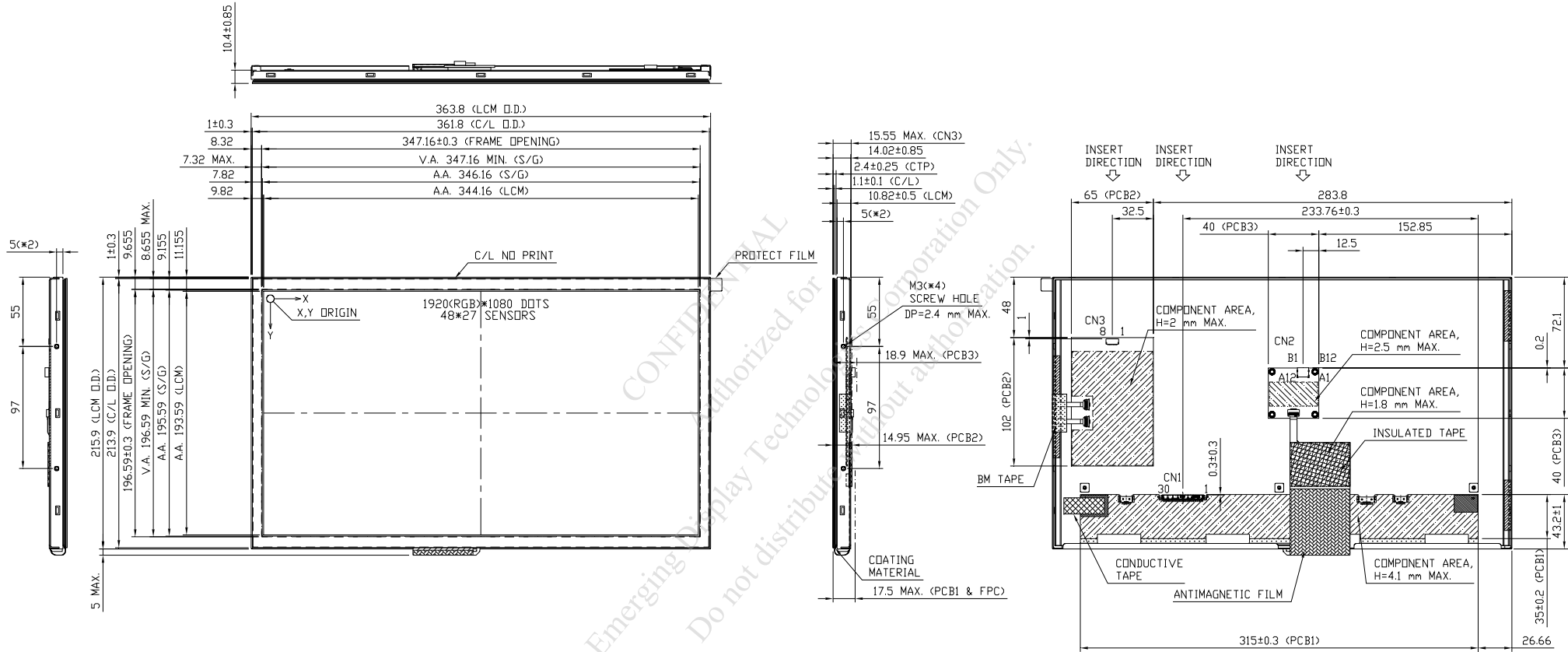

UNIT : mm

SCALE : NTS

THIRD ANGLE PROJECTION

NOT SPECIFIED TOLERANCE IS ± 0.5

NOTE :

1.C/L GLASS : SODA LIME.

2.CN1 : STM MSBKT2407P30HB OR EQUIVALENT.

3.CN2(TYPE C) : SINGATRON 2UB1768-C00111F OR EQUIVALENT.

4.CN3 : JST SM08B-SRSS-TB OR EQUIVALENT.

8. BLOCK DIAGRAM

8.1 LCD MODULE

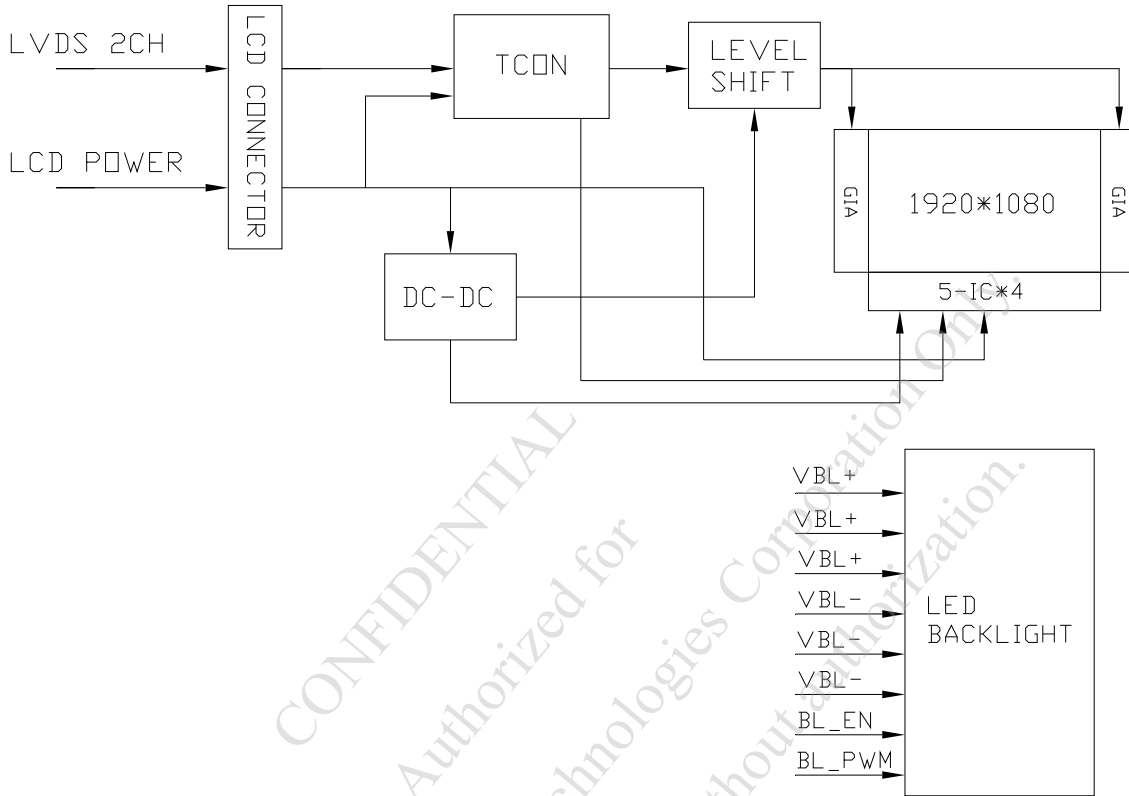

8.2 CTP MODULE

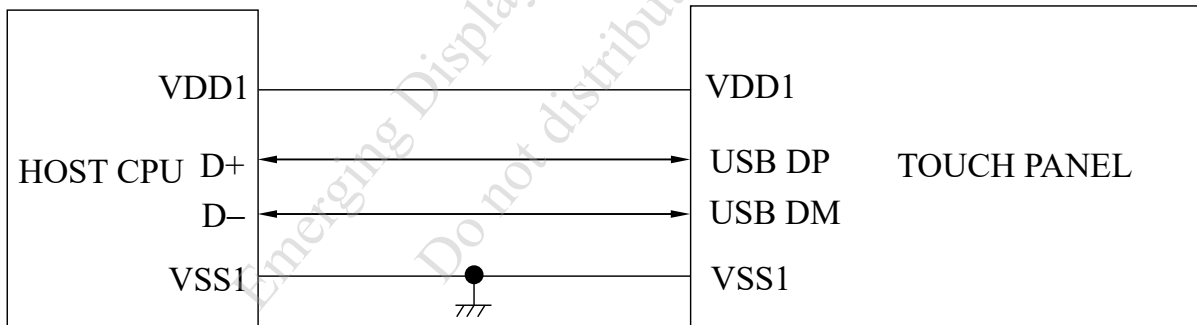

9. DETAIL DRAWING OF DOT MATRIX

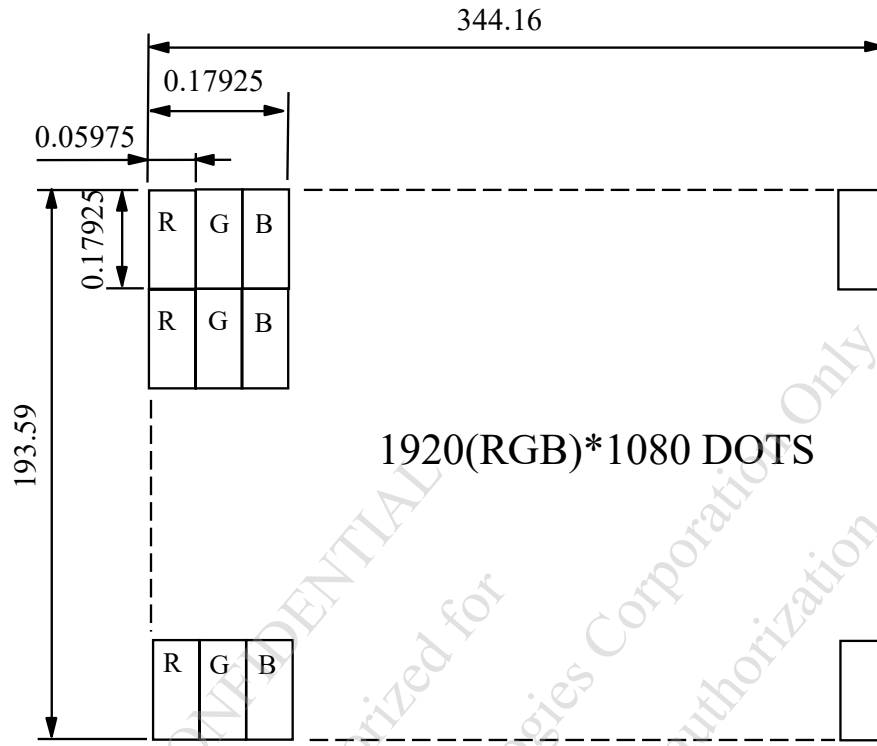

UNIT : mm
SCALE : NTS
NOT SPECIFIED TOLERANCE IS ± 0.1
DOTS MATRIX TOLERANCE IS ± 0.01

CONFIDENTIAL
Authorized for Emerging Display Technologies Corporation Only
Do not distribute without authorization

10. INTERFACE SIGNALS

10.1 LED MODULE INTERFACE(CN1)

PIN NO.	SYMBOL	FUNCTION	REMARKS
1	RxO0-	NEGATIVE LVDS DIFFERENTIAL DATA INPUT (ODD DATA)	
2	RxO0+	POSITIVE LVDS DIFFERENTIAL DATA INPUT (ODD DATA)	
3	RxO1-	NEGATIVE LVDS DIFFERENTIAL DATA INPUT (ODD DATA)	
4	RxO1+	POSITIVE LVDS DIFFERENTIAL DATA INPUT (ODD DATA)	
5	RxO2-	NEGATIVE LVDS DIFFERENTIAL DATA INPUT (ODD DATA)	
6	RxO2+	POSITIVE LVDS DIFFERENTIAL DATA INPUT (ODD DATA)	
7	VSS	GROUND	
8	RxOCLK-	NEGATIVE LVDS DIFFERENTIAL CLOCK INPUT (ODD CLOCK)	
9	RxOCLK+	POSITIVE LVDS DIFFERENTIAL CLOCK INPUT (ODD CLOCK)	
10	RxO3-	NEGATIVE LVDS DIFFERENTIAL DATA INPUT (ODD DATA)	
11	RxO3+	POSITIVE LVDS DIFFERENTIAL DATA INPUT (ODD DATA)	
12	RxE0-	NEGATIVE LVDS DIFFERENTIAL DATA INPUT (EVEN DATA)	
13	RxE0+	POSITIVE LVDS DIFFERENTIAL DATA INPUT (EVEN DATA)	
14	VSS	GROUND	
15	RxE1-	NEGATIVE LVDS DIFFERENTIAL DATA INPUT (EVEN DATA)	
16	RxE1+	POSITIVE LVDS DIFFERENTIAL DATA INPUT (EVEN DATA)	
17	VSS	GROUND	
18	RxE2-	NEGATIVE LVDS DIFFERENTIAL DATA INPUT (EVEN DATA)	
19	RxE2+	POSITIVE LVDS DIFFERENTIAL DATA INPUT (EVEN DATA)	
20	RxECLK-	NEGATIVE LVDS DIFFERENTIAL CLOCK INPUT (EVEN DATA)	
21	RxECLK+	POSITIVE LVDS DIFFERENTIAL CLOCK INPUT (EVEN DATA)	
22	RxE3-	NEGATIVE LVDS DIFFERENTIAL DATA INPUT (EVEN DATA)	
23	RxE3+	POSITIVE LVDS DIFFERENTIAL DATA INPUT (EVEN DATA)	
24	VSS	GROUND	
25	BIST	LCD PANEL SELF TEST ENABLE(3.3V TYP) FOR EDT USE, WHEN IT IS NOT USED, CONNECTING TO GND OR FLOATING IS RECOMMENDED	
26	SDA	I2C-COMPATIBLE SERIAL-DATA INPUT FOR EDT USE , FLOATING IS RECOMMENDED IN THE COSTUMER	
27	SCL	I2C-COMPATIBLE SERIAL-CLOCK INPUT FOR EDT USE , FLOATING IS RECOMMENDED IN THE COSTUMER	
28	VDD	POWER SUPPLY INPUT VOLTAGE(3.3V)	
29	VDD	POWER SUPPLY INPUT VOLTAGE(3.3V)	
30	VDD	POWER SUPPLY INPUT VOLTAGE(3.3V)	

10.2 LED MODULE INTERFACE(CN3)

PIN NO.	SYMBOL	FUNCTION
1	VBL+	POWER SUPPLY VOLTAGE FOR LED DRIVER(+)
2	VBL+	POWER SUPPLY VOLTAGE FOR LED DRIVER(+)
3	VBL+	POWER SUPPLY VOLTAGE FOR LED DRIVER(+)
4	VBL-	POWER SUPPLY VOLTAGE FOR LED DRIVER(-)
5	VBL-	POWER SUPPLY VOLTAGE FOR LED DRIVER(-)
6	VBL-	POWER SUPPLY VOLTAGE FOR LED DRIVER(-)
7	BL_EN	BACKLIGHT LED ON/OFF CONTROL
8	BL_PWM	BACKLIGHT LED BRIGHTNESS CONTROL

10.3 CTP INTERFACE (CN2 USB 2.0 ONLY)

PIN NO.	SYMBOL	FUNCTION
A1	VSS1	GROUND
A2	NC	NON CONNECTION
A3	NC	NON CONNECTION
A4	VDD1	POWER SUPPLY VOLTAGE (+5V)
A5	NC	NON CONNECTION
A6	USB DP	USB D+
A7	USB DM	USB D-
A8	NC	NON CONNECTION
A9	VDD1	POWER SUPPLY VOLTAGE (+5V)
A10	NC	NON CONNECTION
A11	NC	NON CONNECTION
A12	VSS1	GROUND
B1	VSS1	GROUND
B2	NC	NON CONNECTION
B3	NC	NON CONNECTION
B4	VDD1	POWER SUPPLY VOLTAGE (+5V)
B5	NC	NON CONNECTION
B6	USB DP	USB D+
B7	USB DM	USB D-
B8	NC	NON CONNECTION
B9	VDD1	POWER SUPPLY VOLTAGE (+5V)
B10	NC	NON CONNECTION
B11	NC	NON CONNECTION
B12	VSS1	GROUND

11. POWER SUPPLY

11.1 POWER SUPPLY FOR LCM

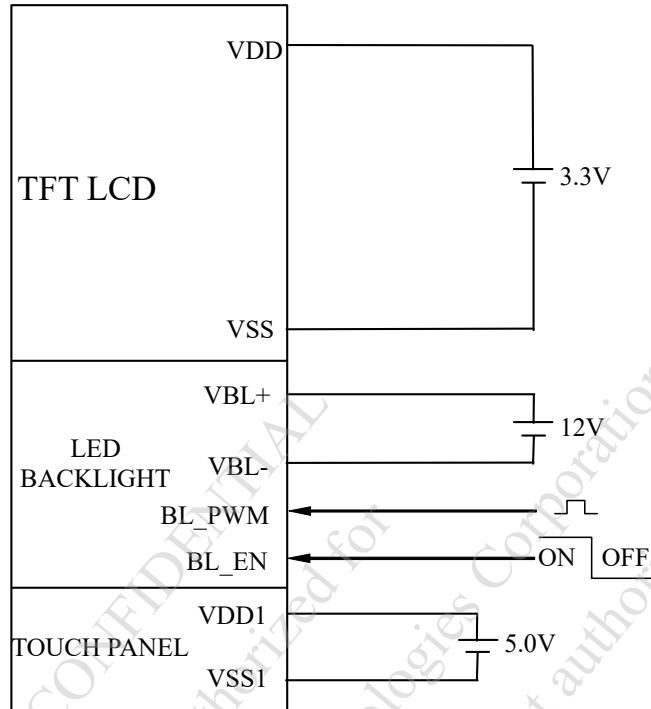

NOTE (1) : ADJUST THE PWM SIGNAL IN ORDER TO CONTROL LED BACKLIGHT'S BRIGHTNESS. THE HIGHER THE DUTY CYCLE, THE HIGHER THE BRIGHTNESS

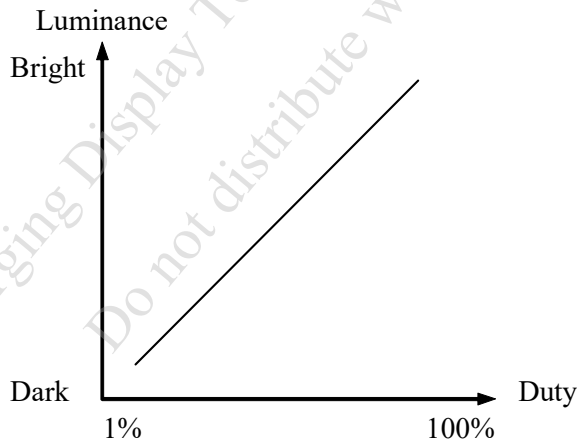

NOTE (2) : PWM SIGNAL OPERATION FREQUENCY IS 100~2000 Hz AND DIMMING DUTY.

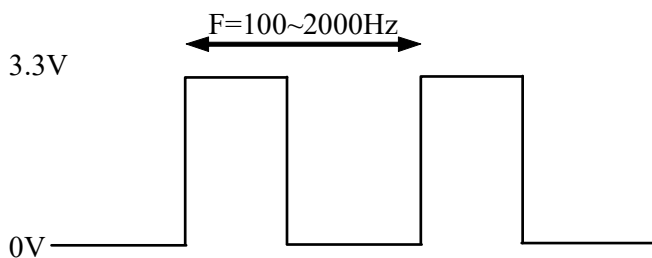

PWM Dimming Frequency[Hz]	Dimming Duty	
	Min[%]	Max[%]
$100 < F_{DIM} < 200$	0.1	100
$200 < F_{DIM} < 500$	0.4	100
$500 < F_{DIM} < 1K$	0.8	100
$1K < F_{DIM} < 2K$	1.5	100

12. CAPACITIVE TOUCH PANEL SPECIFICATION

12.1 OPTICAL CHARACTERISTICS

ITEM	CONDITION	MIN.	TYP.	MAX.	UNIT
TRANSPARENCY NOTE (1)	Ta = 25°C λ=550nm	85	—	—	%

NOTE (1) : OPTICAL MEASUREMENT SHOULD BE EXECUTED AFTER PANEL IS SECURED.
MEASUREMENT PROCESS SHOULD BE EXECUTED IN A STABLE, WINDLESS,
AND DARK ROOM.
OPTICAL SPECIFICATIONS SHOULD BE MEASURED BY SPECTROPHOTOMETER.

12.2 HARDNESS

ITEM	DESCRIPTION
SURFACE HARDNESS	7H (min)

12.3 DURABILITY

USING STEEL BALL AND FALLING ON TOUCH PANEL SURFACE, FROM THE
HEIGHT MUST PASS BELOW CONDITIONS :

ITEM	CONDITION	INSPECTION METHOD	DESCRIPTION
STEEL BALL DROP TEST	WEIGHT : 67g HEIGHT OF FALL : 30 cm	VISUAL INSPECTION	EXPLOSION-PROOF

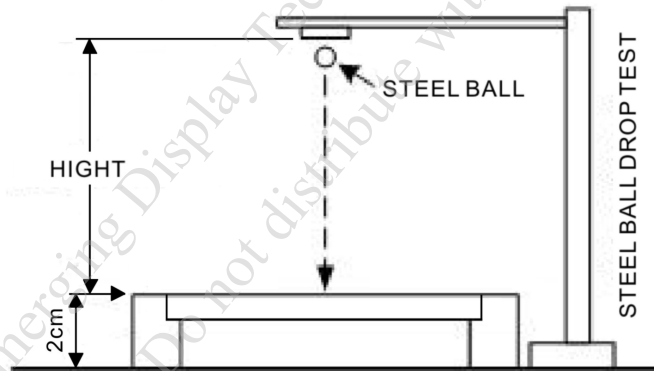

13. INSPECTION CRITERIA

13.1 APPLICATION

THIS INSPECTION STANDARD IS TO BE APPLIED TO THE LCD MODULE DELIVERED FROM EMERGING DISPLAY TECHNOLOGIES CORP.(E.D.T) TO CUSTOMERS

13.2 INSPECTION CONDITIONS

13.2.1 (1)OBSERVATION DISTANCE : 45 ± 5 cm

(2)VIEWING ANGLE : $\pm 45^\circ$

$\pm 45^\circ$ (FOR SECTION WITHIN VIEWING AREA), REFER TO FIG.A
 90° (FOR SECTION OUTSIDE OF VIEWING AREA), REF TO FIG.B
PERPENDICULAR TO MODULE SURFACE

VIEWING ANGLE SHOULD BE SMALLER THAN 45°

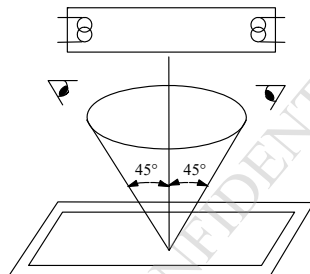

FIG.A

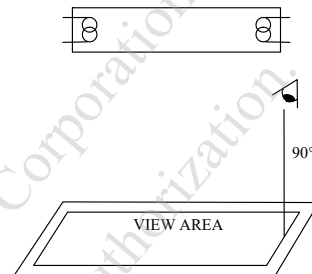

FIG.B

THE INSPECTION CRITERIA IS ACCORDING TO LINE OF SIGHT. INSPECTION SHALL BE MADE WITHIN THE HALF SECTION OF THE VIEWING CONE GENERATED BY LINE SEGMENT OF 45° WITH RESPECT TO THE VERTICAL AXIS FROM CENTER VERTEX OF LCD, THE FLUORESCENT LAMP AND THE CONE AXIS MUST BE PERPENDICULAR TO THE LCD SURFACE.

IF THE DEFECTS ARE OUTSIDE OF VIEWING AREA, IT SHALL BE INSPECTED BY 90° WITH RESPECT TO THE VERTICAL AXIS FROM EDGE OF VIEWING AREA.

13.2.2 ENVIRONMENT CONDITIONS :

AMBIENT TEMPERATURE		$20 \pm 5^\circ\text{C}$
AMBIENT HUMIDITY		$55 \pm 20\% \text{RH}$
AMBIENT ILLUMINATION	COSMETIC INSPECTION	600~800 lux
	FUNCTIONAL INSPECTION	300~500 lux
INSPECTION TIME		15 secs

13.2.3 INSPECTION LOT

QUANTITY PER DELIVERY LOT FOR EACH MODEL

13.2.4 INSPECTION METHOD

A SAMPLING INSPECTION SHALL BE MADE ACCORDING TO THE FOLLOWING PROVISIONS TO JUDGE THE ACCEPTABILITY

(a)APPLICABLE STANDARD :





ANSI/ ASQ Z1.4 NORMAL INSPECTION LEVEL II

(b)AQL : MAJOR DEFECT : AQL 0.65

MINOR DEFECT : AQL 1.5

13.3 DEFECTS CLASSIFICATION

TYPE OF DEFECT	INSPECTION ITEM	DEFECT FEATURE	AQL
MAJOR DEFECT	1.DISPLAY ON	<ul style="list-style-type: none"> • DEFECT TO MISS SPECIFIED DISPLAY FUNCTION, FOR ALL AND SPECIFIED DOTS EX: DISCONNECTION, SHORT CIRCUIT ETC 	0.65
	2.CTP FUNCTION	<ul style="list-style-type: none"> • NO FUNCTION • BROKEN LINE • FALSE TOUCH 	
	3.BACKLIGHT	<ul style="list-style-type: none"> • NO LIGHT • FLICKERING AND OTHER ABNORMAL ILLUMINATION 	
	4.DIMENSIONS	<ul style="list-style-type: none"> • SUBJECT TO INDIVIDUAL ACCEPTANCE SPECIFICATIONS 	
MINOR DEFECT	1.DISPLAY ZONE (VIEWING AREA)	<ul style="list-style-type: none"> • BLACK/WHITE SPOT / CIRCULAR TYPE • BUBBLES ON POLARIZER • NEWTON RING • BLACK/WHITE LINE / LINEAR TYPE • SCRATCH • CONTAMINATION • UNEVEN COLOR SPREAD 	1.0
	2.BEZEL ZONE	<ul style="list-style-type: none"> • STAINS • SCRATCHES • FOREIGN MATTER 	
	3.SOLDERING	<ul style="list-style-type: none"> • INSUFFICIENT SOLDER • SOLDERED IN INCORRECT POSITION • CONVEX SOLDERING SPOT • SOLDER BALLS • SOLDER SCRAPS 	
	4.DISPLAY ON (ALL ON)	<ul style="list-style-type: none"> • LIGHT LINE 	

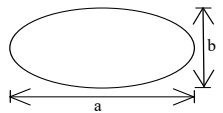
NO.	ITEM	CRITERIA																																								
1	DISPLAY ON INSPECTION	1.INCORRECT PATTERN 2.MISSING SEGMENT 3.DIM SEGMENT 4.OPERATING VOLTAGE BEYOND SPEC																																								
2	OVERALL DIMENSIONS	OVERALL DIMENSION BEYOND SPEC																																								
3	DOT DEFECT	<p>1.INSPECTION PATTERN: FULL WHITE, FULL BLACK, RED, GREEN AND BLUE SCREENS.</p> <p>2.</p> <table border="1"> <thead> <tr> <th colspan="2">ITEM</th> <th>STANDARD</th> </tr> </thead> <tbody> <tr> <td colspan="2"></td> <td>Z</td> </tr> <tr> <td rowspan="3">BRIGHT DOT</td> <td>RANDOM</td> <td>N≤2</td> </tr> <tr> <td>2 DOTS ADJACENT (PAIR)</td> <td>N=0</td> </tr> <tr> <td>3 DOTS ADJACENT OR MORE</td> <td>N=0</td> </tr> <tr> <td rowspan="3">DARK DOT</td> <td>RANDOM</td> <td>N≤4</td> </tr> <tr> <td>2 DOTS ADJACENT (PAIR)</td> <td>N=0</td> </tr> <tr> <td>3 DOTS ADJACENT OR MORE</td> <td>N=0</td> </tr> <tr> <td rowspan="2">DISTANCE</td> <td>MINIMUM DISTANCE BETWEEN BRIGHT DOTS</td> <td>—</td> </tr> <tr> <td>MINIMUM DISTANCE BETWEEN DARK DOTS</td> <td>L≥5mm</td> </tr> <tr> <td colspan="2">TOTAL BRIGHT AND DARK DOT</td> <td>N≤6</td> </tr> <tr> <td colspan="2">SMALL BRIGHT DOT</td> <td>N≤3 DISTANCE≤5mm N≤5 DISTANCE≥5mm</td> </tr> <tr> <td colspan="2">MICRO BRIGHT DOT(ND 8% NOT OBSERVED)</td> <td>N=0</td> </tr> <tr> <td colspan="2">DISPLAY FAILURE (V-LINE/H-LINE/CROSS LINE ETC.)</td> <td>NOT ALLOWABLE</td> </tr> <tr> <td>MURA</td> <td>JUDGE BY LIMIT SAMPLE OR NOT VISIBLE THROUGH ND FILTER</td> <td>ND 5%</td> </tr> </tbody> </table> <p>NOTE :</p> <ol style="list-style-type: none"> THE DEFINITION OF DOT: DOTS THAT CAN BE SEEN THROUGH A 8% ND FILTER,AND THE SIZE OF A DEFECTIVE DOT OVER IS 1/2 OF WHOLE DOT. BRIGHT DOT: DOTS THAT CAN BE SEEN THROUGH A 8% ND FILTER, AND THE SIZE OF A DEFECTIVE DOT IS THE WHOLE DOT. DARK DOT: DOTS APPEAR DARK AND UNCHANGED IN SIZE IN WHICH LCD PANEL IS DISPLAYING UNDER PURE RED, GREEN, BLUE PICTURE. MICRO BRIGHT DOT: DOTS THAT CANNOT BE SEEN THROUGH A 8% ND FILTER, AND THE SIZE OF A DEFECTIVE DOT IS THE WHOLE DOT. SMALL BRIGHT DOT: THE SIZE OF A DEFECTIVE DOT IS LESS THAN 1/2 OF WHOLE DOT. <p>6.2 DOT ADJACENT=1PAIR=2DOTS.</p> <div style="display: flex; justify-content: space-around; align-items: center;"> <div style="text-align: center;">  2 dot adjacent </div> <div style="text-align: center;">  2 dot adjacent </div> <div style="text-align: center;">  2 dot adjacent(vertical) </div> <div style="text-align: center;">  2 dot adjacent(slant) </div> </div>	ITEM		STANDARD			Z	BRIGHT DOT	RANDOM	N≤2	2 DOTS ADJACENT (PAIR)	N=0	3 DOTS ADJACENT OR MORE	N=0	DARK DOT	RANDOM	N≤4	2 DOTS ADJACENT (PAIR)	N=0	3 DOTS ADJACENT OR MORE	N=0	DISTANCE	MINIMUM DISTANCE BETWEEN BRIGHT DOTS	—	MINIMUM DISTANCE BETWEEN DARK DOTS	L≥5mm	TOTAL BRIGHT AND DARK DOT		N≤6	SMALL BRIGHT DOT		N≤3 DISTANCE≤5mm N≤5 DISTANCE≥5mm	MICRO BRIGHT DOT(ND 8% NOT OBSERVED)		N=0	DISPLAY FAILURE (V-LINE/H-LINE/CROSS LINE ETC.)		NOT ALLOWABLE	MURA	JUDGE BY LIMIT SAMPLE OR NOT VISIBLE THROUGH ND FILTER	ND 5%
ITEM		STANDARD																																								
		Z																																								
BRIGHT DOT	RANDOM	N≤2																																								
	2 DOTS ADJACENT (PAIR)	N=0																																								
	3 DOTS ADJACENT OR MORE	N=0																																								
DARK DOT	RANDOM	N≤4																																								
	2 DOTS ADJACENT (PAIR)	N=0																																								
	3 DOTS ADJACENT OR MORE	N=0																																								
DISTANCE	MINIMUM DISTANCE BETWEEN BRIGHT DOTS	—																																								
	MINIMUM DISTANCE BETWEEN DARK DOTS	L≥5mm																																								
TOTAL BRIGHT AND DARK DOT		N≤6																																								
SMALL BRIGHT DOT		N≤3 DISTANCE≤5mm N≤5 DISTANCE≥5mm																																								
MICRO BRIGHT DOT(ND 8% NOT OBSERVED)		N=0																																								
DISPLAY FAILURE (V-LINE/H-LINE/CROSS LINE ETC.)		NOT ALLOWABLE																																								
MURA	JUDGE BY LIMIT SAMPLE OR NOT VISIBLE THROUGH ND FILTER	ND 5%																																								
4	BUBBLES ON POLARIZER /SURFACE STAINS /DIRT/CF FAIL/SPOT	<table border="1"> <thead> <tr> <th></th> <th>AVERAGE DIAMETER (mm) : D</th> <th>NUMBER OF PIECES PERMITTED</th> </tr> </thead> <tbody> <tr> <td rowspan="3">BUBBLE ON THE POLARIZER</td> <td>D ≤ 0.25</td> <td>IGNORE</td> </tr> <tr> <td>0.25 < D ≤ 0.5</td> <td>4</td> </tr> <tr> <td>D > 0.5</td> <td>0</td> </tr> <tr> <td rowspan="3">POLARIZER SCRATCH</td> <td>W < 0.05</td> <td>IGNORE</td> </tr> <tr> <td>0.05 < W ≤ 0.1, 2 < L ≤ 5</td> <td>4</td> </tr> <tr> <td>W > 0.1</td> <td>0</td> </tr> <tr> <td rowspan="3">CF FAIL / SPOT</td> <td>D < 0.25</td> <td>IGNORE</td> </tr> <tr> <td>0.25 < D ≤ 0.5</td> <td>4</td> </tr> <tr> <td>D > 0.5</td> <td>0</td> </tr> </tbody> </table> <p>NOTE : (1)POLARIZER BUBBLE IS DEFINED AS THE BUBBLE APPEARS ON ACTIVE DISPLAY AREA. THE DEFECT OF POLARIZER BUBBLE SHALL BE IGNORED IF THE POLARIZER BUBBLE APPEARS ON THE OUTSIDE OF ACTIVE DISPLAY AREA.</p> <p>(2)THE EXTRANEIOUS SUBSTANCE IS DEFINED AS IT CAN BE OBSERVED WHEN THE MODULE IS POWER ON.</p> <p>(3)THE DEFINITION OF AVERAGE DIAMETER, D IS DEFINED AS FOLLOWING.</p> <p>AVERAGE DIAMETER (D)=(a+b)/2</p> <div style="text-align: center;">  </div>		AVERAGE DIAMETER (mm) : D	NUMBER OF PIECES PERMITTED	BUBBLE ON THE POLARIZER	D ≤ 0.25	IGNORE	0.25 < D ≤ 0.5	4	D > 0.5	0	POLARIZER SCRATCH	W < 0.05	IGNORE	0.05 < W ≤ 0.1, 2 < L ≤ 5	4	W > 0.1	0	CF FAIL / SPOT	D < 0.25	IGNORE	0.25 < D ≤ 0.5	4	D > 0.5	0																
	AVERAGE DIAMETER (mm) : D	NUMBER OF PIECES PERMITTED																																								
BUBBLE ON THE POLARIZER	D ≤ 0.25	IGNORE																																								
	0.25 < D ≤ 0.5	4																																								
	D > 0.5	0																																								
POLARIZER SCRATCH	W < 0.05	IGNORE																																								
	0.05 < W ≤ 0.1, 2 < L ≤ 5	4																																								
	W > 0.1	0																																								
CF FAIL / SPOT	D < 0.25	IGNORE																																								
	0.25 < D ≤ 0.5	4																																								
	D > 0.5	0																																								

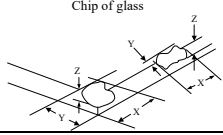
NO.	ITEM	CRITERIA											
5	BLACK/WHITE SPOT CIRCULAR TYPE	<p>THE FOLLOWING BLACK/WHITE SPOT ARE WITHIN THE VIEWING AREA. AVERAGE DIAMETER : D (mm)</p> <table border="1"> <thead> <tr> <th>SIZE D</th> <th>PERMISSIBLE NO.</th> </tr> </thead> <tbody> <tr> <td>$D \leq 0.2\text{mm}$</td> <td>IGNORE</td> </tr> <tr> <td>$0.2\text{mm} < D \leq 0.3\text{mm}$</td> <td>8</td> </tr> <tr> <td>$0.3\text{mm} < D \leq 0.5\text{mm}$</td> <td>8</td> </tr> <tr> <td>$D > 0.5\text{mm}$</td> <td>0</td> </tr> </tbody> </table> <p>NOTE (1) : THE DISTANCE BETWEEN DEFECTS SHOULD BE MORE THAN 10mm APART.</p>		SIZE D	PERMISSIBLE NO.	$D \leq 0.2\text{mm}$	IGNORE	$0.2\text{mm} < D \leq 0.3\text{mm}$	8	$0.3\text{mm} < D \leq 0.5\text{mm}$	8	$D > 0.5\text{mm}$	0
SIZE D	PERMISSIBLE NO.												
$D \leq 0.2\text{mm}$	IGNORE												
$0.2\text{mm} < D \leq 0.3\text{mm}$	8												
$0.3\text{mm} < D \leq 0.5\text{mm}$	8												
$D > 0.5\text{mm}$	0												
6	SCRATCH	<p>THE FOLLOWING BLACK LINE, WHITE LINE IS WITHIN THE VIEWING AREA. WIDTH : W (mm) , LENGTH : L (mm)</p> <table border="1"> <thead> <tr> <th>SIZE W & L</th> <th>PERMISSIBLE NO.</th> </tr> </thead> <tbody> <tr> <td>$W \leq 0.07\text{mm}$</td> <td>IGNORE</td> </tr> <tr> <td>$0.07\text{mm} < W \leq 0.1\text{mm}, L \leq 10\text{mm}$</td> <td>5</td> </tr> <tr> <td>$0.1\text{mm} < W \leq 0.15\text{mm}, L \leq 15\text{mm}$</td> <td>3</td> </tr> <tr> <td>$W > 0.15\text{mm}$</td> <td>0</td> </tr> </tbody> </table> <p>NOTE (1) : THE DISTANCE BETWEEN DEFECTS SHOULD BE MORE THAN 10mm APART.</p>		SIZE W & L	PERMISSIBLE NO.	$W \leq 0.07\text{mm}$	IGNORE	$0.07\text{mm} < W \leq 0.1\text{mm}, L \leq 10\text{mm}$	5	$0.1\text{mm} < W \leq 0.15\text{mm}, L \leq 15\text{mm}$	3	$W > 0.15\text{mm}$	0
SIZE W & L	PERMISSIBLE NO.												
$W \leq 0.07\text{mm}$	IGNORE												
$0.07\text{mm} < W \leq 0.1\text{mm}, L \leq 10\text{mm}$	5												
$0.1\text{mm} < W \leq 0.15\text{mm}, L \leq 15\text{mm}$	3												
$W > 0.15\text{mm}$	0												
7	BLACK / WHITE LINE LINEAR TYPE / FOREIGN FIBER	<p>THE FOLLOWING BLACK LINE, WHITE LINE IS WITHIN THE VIEWING AREA. WIDTH : W (mm) , LENGTH : L (mm)</p> <table border="1"> <thead> <tr> <th>SIZE W & L</th> <th>PERMISSIBLE NO.</th> </tr> </thead> <tbody> <tr> <td>$W \leq 0.07\text{mm}$</td> <td>IGNORE</td> </tr> <tr> <td>$0.07\text{mm} < W \leq 0.1\text{mm}, L \leq 10\text{mm}$</td> <td>5</td> </tr> <tr> <td>$0.1\text{mm} < W \leq 0.15\text{mm}, L \leq 15\text{mm}$</td> <td>3</td> </tr> <tr> <td>$W > 0.15\text{mm}$</td> <td>0</td> </tr> </tbody> </table> <p>NOTE (1) : THE DISTANCE BETWEEN DEFECTS SHOULD BE MORE THAN 10mm APART.</p>		SIZE W & L	PERMISSIBLE NO.	$W \leq 0.07\text{mm}$	IGNORE	$0.07\text{mm} < W \leq 0.1\text{mm}, L \leq 10\text{mm}$	5	$0.1\text{mm} < W \leq 0.15\text{mm}, L \leq 15\text{mm}$	3	$W > 0.15\text{mm}$	0
SIZE W & L	PERMISSIBLE NO.												
$W \leq 0.07\text{mm}$	IGNORE												
$0.07\text{mm} < W \leq 0.1\text{mm}, L \leq 10\text{mm}$	5												
$0.1\text{mm} < W \leq 0.15\text{mm}, L \leq 15\text{mm}$	3												
$W > 0.15\text{mm}$	0												
8	BUBBLE / DENT FOR OPTICAL BONDING	<p>BUBBLES WITHIN VIEWING AREA. AVERAGE DIAMETER : D (mm)</p> <table border="1"> <thead> <tr> <th>SIZE D</th> <th>PERMISSIBLE NO.</th> </tr> </thead> <tbody> <tr> <td>$D \leq 0.2\text{mm}$</td> <td>IGNORE</td> </tr> <tr> <td>$0.2\text{mm} < D \leq 0.3\text{mm}$</td> <td>3</td> </tr> <tr> <td>$0.3\text{mm} < D \leq 0.5\text{mm}$</td> <td>1</td> </tr> <tr> <td>$D > 0.5\text{mm}$</td> <td>0</td> </tr> </tbody> </table> <p>NOTE (1) : THE DISTANCE BETWEEN DEFECTS SHOULD BE MORE THAN 10mm APART.</p>		SIZE D	PERMISSIBLE NO.	$D \leq 0.2\text{mm}$	IGNORE	$0.2\text{mm} < D \leq 0.3\text{mm}$	3	$0.3\text{mm} < D \leq 0.5\text{mm}$	1	$D > 0.5\text{mm}$	0
SIZE D	PERMISSIBLE NO.												
$D \leq 0.2\text{mm}$	IGNORE												
$0.2\text{mm} < D \leq 0.3\text{mm}$	3												
$0.3\text{mm} < D \leq 0.5\text{mm}$	1												
$D > 0.5\text{mm}$	0												
9	CHIPPING	<table border="1"> <tbody> <tr> <td>CORNER</td> <td>$X \leq 3\text{mm} \cdot Y \leq 3\text{mm} \cdot Z \leq t$ (t : THICKNESS)</td> </tr> <tr> <td>EDGE</td> <td>$X \leq 6\text{mm} \cdot Y \leq 1\text{mm} \cdot Z < t$ (t : THICKNESS)</td> </tr> </tbody> </table>	CORNER	$X \leq 3\text{mm} \cdot Y \leq 3\text{mm} \cdot Z \leq t$ (t : THICKNESS)	EDGE	$X \leq 6\text{mm} \cdot Y \leq 1\text{mm} \cdot Z < t$ (t : THICKNESS)	 <p>Chip of glass</p>						
CORNER	$X \leq 3\text{mm} \cdot Y \leq 3\text{mm} \cdot Z \leq t$ (t : THICKNESS)												
EDGE	$X \leq 6\text{mm} \cdot Y \leq 1\text{mm} \cdot Z < t$ (t : THICKNESS)												
10	CRACKED GLASS	NOT ACCEPTABLE											
11	LINE DEFECT ON DISPLAY	OBVIOUS VERTICAL OR HORIZONTAL LINE DEFECT IS NOT ALLOWED.											
12	MURA ON DISPLAY	IT'S ACCEPTABLE, IF MURA IS SLIGHT VISIBLE THROUGH 5% ND FILTER.											
13	UNEVEN COLOR SPREAD, COLORATION	TO BE DETERMINED BASED UPON THE LIMITED SAMPLE.											
14	BEZEL APPEARANCE	<p>1. BEZEL MAY NOT HAVE RUST, BE DEFORMED OR HAVE FINGER PRINTS STAINS OF OTHER CONTAMINATION.</p> <p>2. BEZEL MUST COMPLY WITH JOB SPECIFICATIONS.</p>											

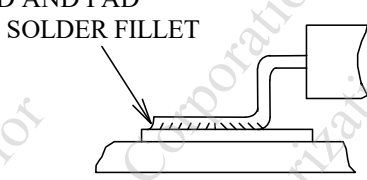
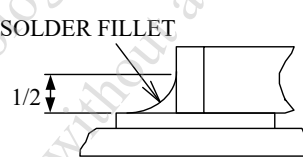
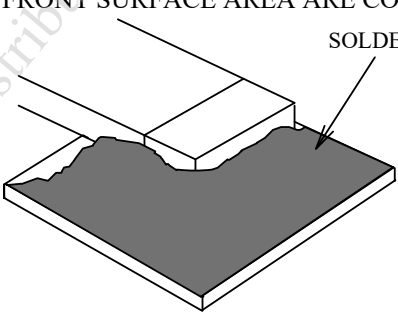
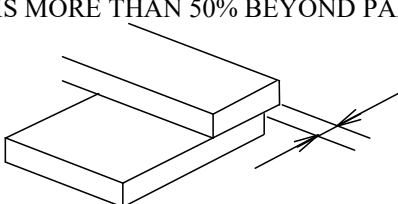
NO.	ITEM	CRITERIA
15	PCB	<ol style="list-style-type: none"> 1. THERE MAY NOT BE MORE THAN 2mm OF SEALANT OUTSIDE THE SEAL AREA ON THE PCB, AND THERE SHOULD BE NO MORE THAN THREE PLACES. 2. NO OXIDATION OR CONTAMINATION ON PCB TERMINALS. 3. PARTS ON PCB MUST BE THE SAME AS ON THE PRODUCTION CHARACTERISTIC CHART. THERE SHOULD BE NO WRONG PARTS, MISSING PARTS OR EXCESS PARTS. 4. THE JUMPER ON THE PCB SHOULD CONFORM TO THE PRODUCT CHARACTERISTIC CHART. 5. IF SOLDER GETS ON BEZEL TAB PADS, LED PAD, ZEBRA PAD OR SCREW HOLD PAD; MAKE SURE IT IS SMOOTHED DOWN.
16	SOLDERING	<ol style="list-style-type: none"> 1. NO SOLDERING FOUND ON THE SPECIFIED PLACE 2. INSUFFICIENT SOLDER <ol style="list-style-type: none"> (a) LSI, IC A POOR WETTING OF SOLDER IS BETWEEN LOWER BEND OR "HEEL" OF LEAD AND PAD  (b) CHIP COMPONENT <ul style="list-style-type: none"> · SOLDER IS LESS THAN 50% OF SIDES AND FRONT FACE WETTING  · SOLDER WETS 3 SIDES OF TERMINAL, BUT LESS THAN 25% OF SIDES AND FRONT SURFACE AREA ARE COVERED  3. PARTS ALIGNMENT <ol style="list-style-type: none"> (a) LSI, IC LEAD WIDTH IS MORE THAN 50% BEYOND PAD OUTLINE 

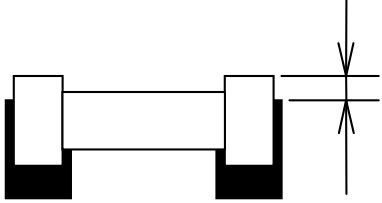
NO.	ITEM	CRITERIA
16	SOLDERING	<p>(b)CHIP COMPONENT COMPONENT IS OFF CENTER, AND MORE THAN 50% OF THE LEADS IS OFF THE PAD OUTLINE</p>  <p>4. NO UNMELTED SOLDER PASTE MAY BE PRESENT ON THE PCB. 5. NO COLD SOLDER JOINTS, MISSING SOLDER CONNECTIONS, OXIDATION OR ICICLE. 6. NO RESIDUE OR SOLDER BALLS ON PCB. 7. NO SHORT CIRCUITS IN COMPONENTS ON PCB.</p>
17	BACKLIGHT	<p>1. NO LIGHT 2. FLICKERING AND OTHER ABNORMAL ILLUMINATION 3. SPOTS OR SCRATCHES THAT APPEAR WHEN LIT MUST BE JUDGED USING LCD SPOT, LINES AND CONTAMINATION STANDARDS. 4. BACKLIGHT DOESN'T LIGHT OR COLOR IS WRONG.</p>
18	GENERAL APPEARANCE	<p>1. NO OXIDATION, CONTAMINATION, CURVES OR, BENDS ON INTERFACE PIN (OLB) OF TCP. 2. NO CRACKS ON INTERFACE PIN (OLB) OF TCP. 3. NO CONTAMINATION, SOLDER RESIDUE OR SOLDER BALLS ON PRODUCT. 4. THE IC ON THE TCP MAY NOT BE DAMAGED, CIRCUITS. 5. THE UPPERMOST EDGE OF THE PROTECTIVE STRIP ON THE INTERFACE PIN MUST BE PRESENT OR LOOK AS IF IT CAUSE THE INTERFACE PIN TO SEVER. 6. THE RESIDUAL ROSIN OR TIN OIL OF SOLDERING (COMPONENT OR CHIP COMPONENT) IS NOT BURNED INTO BROWN OR BLACK COLOR. 7. SEALANT ON TOP OF THE ITO CIRCUIT HAS NOT HARDENED. 8. PIN TYPE MUST MATCH TYPE IN SPECIFICATION SHEET. 9. LCD PIN LOOSE OR MISSING PINS. 10. PRODUCT PACKAGING MUST BE THE SAME AS SPECIFIED ON PACKAGING SPECIFICATION SHEET. 11. PRODUCT DIMENSION AND STRUCTURE MUST CONFORM TO PRODUCT SPECIFICATION SHEET. 12. THE APPEARANCE OF HEAT SEAL SHOULD NOT ADMIT ANY DIRT AND BREAK.</p>

NOTE (1) : FOR ANY SPOTS OR LINES, WHICH ARE NOT OBSERVED UNDER APPROPRIATE PANEL
OPERATING CONDITION ARE DEEMED ACCEPTABLE.

NOTE (2) : THE FOREIGN MATERIALS THAT CAN BE BLOWN OUT BY AIR AND REMOVED BY WET
CLEANING ARE NOT REGARDED AS DEFECTS.

14. RELIABILITY TEST

14.1 STANDARD SPECIFICATIONS FOR RELIABILITY OF LCD MODULE

NO.	ITEM	DESCRIPTION
1	HIGH TEMPERATURE TEST (OPERATION)	THE SAMPLE SHOULD BE ALLOWED TO STAND AT +85°C FOR 240 HRS
2	LOW TEMPERATURE TEST (OPERATION)	THE SAMPLE SHOULD BE ALLOWED TO STAND AT -30°C FOR 240 HRS
3	HIGH TEMPERATURE TEST (STORAGE)	THE SAMPLE SHOULD BE ALLOWED TO STAND AT +85°C FOR 240 HRS
4	LOW TEMP TEST (STORAGE)	THE SAMPLE SHOULD BE ALLOWED TO STAND AT -30°C FOR 240 HRS
5	HIGH TEMPERATURE /HUMIDITY TEST (STORAGE)	THE SAMPLE SHOULD BE ALLOWED TO STAND AT 40°C , 90% RH 240 HRS
6	THERMAL SHOCK (NOT OPERATED)	<p>THE SAMPLE SHOULD BE ALLOWED TO STAND THE FOLLOWING 10 CYCLES OF OPERATION:</p> <p>The diagram shows a thermal shock cycle. It starts at -30°C, ramps up to +85°C in 3 minutes, stays at +85°C for 30 minutes, ramps down to -30°C in 3 minutes, and stays at -30°C for 30 minutes. This sequence is labeled as '1 CYCLE' and is repeated 10 times.</p>
7	ESD (ELECTROSTATIC DISCHARGE) (NOT OPERATED)	AIR DISCHARGE ± 12KV CONTACT DISCHARGE ± 8KV (ACCORDING TO IEC-61000-4-2)

NOTE (1) : THE TEST SAMPLES HAVE RECOVERY TIME FOR 2 HOURS AT ROOM TEMPERATURE BEFORE THE FUNCTION CHECK. IN THE STANDARD CONDITIONS, THERE IS NO DISPLAY FUNCTION NG ISSUE OCCURRED.

NOTE (2) : WHEN THE LCD MODULE IS OPERATED AT AMBIENT TEMPERATURE 80°C, THE PWM DUTY CYCLE OF THE LED BACKLIGHT SHOULD BE ADJUSTED TO BE LESS THAN TBD. IF THE MODULE IS OPERATED AT A HIGHER DUTY CYCLE THAN TBD, THEN THERE IS A POSSIBILITY OF DISTORTION AND IRREGULARITY OF THE PICTURE DUE TO LIQUID CRYSTAL BEHAVIOR.

NOTE (3) : TESTING CONDITIONS AND INSPECTION CRITERIA

NO.	ITEM	TEST MODEL	INSPECTION CRITERIA
1	CURRENT CONSUMPTION	REFER TO SPECIFICATION	THE CURRENT CONSUMPTION SHOULD CONFORM TO THE PRODUCT SPECIFICATION.
2	CONTRAST	REFER TO SPECIFICATION	AFTER THE TESTS HAVE BEEN EXECUTED, THE CONTRAST MUST BE LARGER THAN HALF OF ITS INITIAL VALUE PRIOR TO THE TESTS.
3	APPEARANCE	VISUAL INSPECTION	DEFECT FREE

15. CAUTION

15.1 OPERATION

- 15.1.1 DO NOT CONNECT OR DISCONNECT MODULES TO OR FROM THE MAIN SYSTEM WHILE POWER IS BEING SUPPLIED .
- 15.1.2 USE THE MODULE WITHIN SPECIFIED TEMPERATURE ; LOWER TEMPERATURE CAUSES THE RETARDATION OF BLINKING SPEED OF THE DISPLAY ; HIGHER TEMPERATURE MAKES OVERALL DISPLAY DISCOLOR . WHEN THE TEMPERATURE RETURNS TO NORMALITY, THE DISPLAY WILL OPERATE NORMALLY.
- 15.1.3 ADJUST THE LC DRIVING VOLTAGE TO OBTAIN THE OPTIMUM CONTRAST .
- 15.1.4 POWER ON SEQUENCE INPUT SIGNALS SHOULD NOT BE SUPPLIED TO LCD MODULE BEFORE POWER SUPPLY VOLTAGE IS APPLIED AND REACHES THE SPECIFIED VALUE.
IF ABOVE SEQUENCE IS NOT FOLLOWED , CMOS LSIS OF LCD MODULES MAY BE DAMAGED DUE TO LATCH - UP PROBLEM.
- 15.1.5 NOT ALLOWED TO INFLICT ANY EXTERNAL STRESS AND TO CAUSE ANY MECHANICAL INTERFERENCE ON THE BENDING AREA OF FPC DURING THE TAIL BENDING BACKWARDS!
DO NOT STRESS FPC AND IC ON THE MODULE!

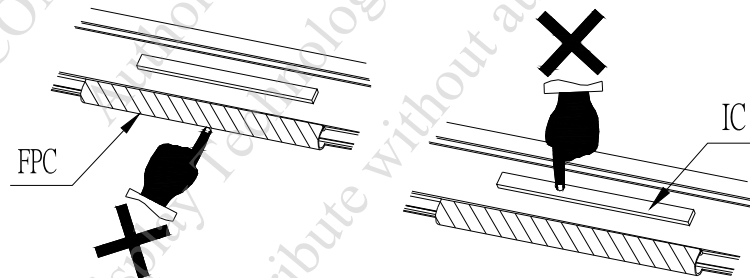

15.2 NOTICE

- 15.2.1 USE A GROUNDED SOLDERING IRON WHEN SOLDERING CONNECTOR I/O TERMINALS . FOR SOLDERING OR REPAIRING, TAKE PRECAUTION AGAINST THE TEMPERATURE OF THE SOLDERING IRON AND THE SOLDERING TIME TO PREVENT PEELING OFF THE THROUGH-HOLE-PAD .
- 15.2.2 DO NOT DISASSEMBLE . EDT SHALL NOT BE HELD RESPONSIBLE IF THE MODULE IS DISASSEMBLED AND UPON THE REASSEMBLY THE MODULE FAILED.
- 15.2.3 DO NOT CHARGE STATIC ELECTRICITY, AS THE CIRCUIT OF THIS MODULE CONTAINS CMOS LSIS. A WORKMAN'S BODY SHOULD ALWAYS BE STATIC-PROTECTED BY USE OF AN ESD STRAP. WORKING CLOTHES FOR SUCH PERSONNEL SHOULD BE OF STATIC-PROTECTED MATERIAL.
- 15.2.4 ALWAYS GROUND THE ELECTRICALLY-POWERED DRIVER BEFORE USING IT TO INSTALL THE LCD MODULE. WHILE CLEANING THE WORK STATION BY VACUUM CLEANER, DO NOT BRING THE SUCKING MOUTH NEAR THE MODULE ; STATIC ELECTRICITY OF THE ELECTRICALLY-POWERED DRIVER OR THE VACUUM CLEANER MAY DESTROY THE MODULE.
- 15.2.5 DON'T GIVE EXTERNAL SHOCK.
- 15.2.6 DON'T APPLY EXCESSIVE FORCE ON THE SURFACE.
- 15.2.7 LIQUID IN LCD IS HAZARDOUS SUBSTANCE. MUST NOT LICK AND SWALLOW.
WHEN THE LIQUID IS ATTACH TO YOUR, SKIN, CLOTH ETC. WASH IT OUT THOROUGHLY AND IMMEDIATELY.
- 15.2.8 DON'T OPERATE IT ABOVE THE ABSOLUTE MAXIMUM RATING.
- 15.2.9 STORAGE IN A CLEAN ENVIRONMENT, FREE FROM DUST, ACTIVE GAS, AND SOLVENT.
- 15.2.10 STORE WITHOUT ANY PHYSICAL LOAD.
- 15.2.11 REWIRING: NO MORE THAN 3 TIMES.