

EXAMINED BY :	EMERGING DISPLAY TECHNOLOGIES CORPORATION	FILE NO . CAS-0009566
Lucica Lu		ISSUE : OCT.17, 2023
APPROVED BY:		TOTAL PAGE : 21
Vincent Wu		VERSION : 3

CUSTOMER ACCEPTANCE SPECIFICATIONS

MODEL NO. :
ET121025HDXA
 (RoHS)
 FOR MESSRS :

CUSTOMER'S APPROVAL

DATE :

BY :

RECORDS OF REVISION	DOC . FIRST ISSUE	AUG.16, 2023
---------------------	-------------------	--------------

DATE	REVISED PAGE NO.	SUMMARY														
SEP.21, 2023	8	8. BLOCK DIAGRAM 13.NC→CEC														
	10	10.1 CN1(HDMI) <table border="1" style="margin-left: 20px;"> <tr> <th>PIN NO.</th> <th>SYMBOL</th> <th>FUNCTION</th> </tr> <tr> <td>13</td> <td>NC</td> <td>NON CONNECTION</td> </tr> <tr> <td colspan="3" style="text-align: center;">↓</td> </tr> <tr> <th>PIN NO.</th> <th>SYMBOL</th> <th>FUNCTION</th> </tr> <tr> <td>13</td> <td>CEC</td> <td>CONSUMER ELECTRONICS CONTROL</td> </tr> </table>	PIN NO.	SYMBOL	FUNCTION	13	NC	NON CONNECTION	↓			PIN NO.	SYMBOL	FUNCTION	13	CEC
PIN NO.	SYMBOL	FUNCTION														
13	NC	NON CONNECTION														
↓																
PIN NO.	SYMBOL	FUNCTION														
13	CEC	CONSUMER ELECTRONICS CONTROL														
OCT.17, 2023	8	8. BLOCK DIAGRAM 13.CEC→NC														
	10	10.1 CN1(HDMI) <table border="1" style="margin-left: 20px;"> <tr> <th>PIN NO.</th> <th>SYMBOL</th> <th>FUNCTION</th> </tr> <tr> <td>13</td> <td>CEC</td> <td>CONSUMER ELECTRONICS CONTROL</td> </tr> <tr> <td colspan="3" style="text-align: center;">↓</td> </tr> <tr> <th>PIN NO.</th> <th>SYMBOL</th> <th>FUNCTION</th> </tr> <tr> <td>13</td> <td>NC</td> <td>NON CONNECTION</td> </tr> </table>	PIN NO.	SYMBOL	FUNCTION	13	CEC	CONSUMER ELECTRONICS CONTROL	↓			PIN NO.	SYMBOL	FUNCTION	13	NC
PIN NO.	SYMBOL	FUNCTION														
13	CEC	CONSUMER ELECTRONICS CONTROL														
↓																
PIN NO.	SYMBOL	FUNCTION														
13	NC	NON CONNECTION														

CONFIDENTIAL
 Authorized for
 Emerging Display Technologies Corporation Only.
 Do not distribute without authorization.

TABLE OF CONTENTS

NO.	ITEM	PAGE
1.	GENERAL SPECIFICATIONS -----	1
2.	MECHANICAL SPECIFICATIONS -----	1
3.	ABSOLUTE MAXIMUM RATINGS -----	2
4.	ELECTRICAL CHARACTERISTICS -----	3
5.	TIMING CHARACTERISTICS -----	4
6.	OPTICAL CHARACTERISTICS -----	5, 6
7.	OUTLINE DIMENSIONS -----	7
8.	BLOCK DIAGRAM -----	8
9.	DETAIL DRAWING OF DOT MATRIX -----	9
10.	INTERFACE SIGNALS -----	10
11.	POWER SUPPLY -----	11
12.	INSPECTION CRITERIA -----	12~18
13.	RELIABILITY TEST -----	19
14.	CAUTION -----	20, 21

CONFIDENTIAL
Authorized for Emerging Display Technologies Corporation Only.
Do not distribute without authorization.

1. GENERAL SPECIFICATIONS

1.1 MATERIAL SAFETY DESCRIPTION

ASSEMBLIES SHALL COMPLY WITH EUROPEAN ROHS REQUIREMENTS, INCLUDING PROHIBITED MATERIALS/COMPONENTS CONTAINING LEAD, MERCURY, CADMIUM, HEXAVALENT CHROMIUM, POLYBROMINATED BIPHENYLS (PBB) AND POLYBROMINATED DIPHENYL ETHERS (PBDE), BIS(2-ETHYLHEXYL) PHTHALATE (DEHP), BUTYL BENZYL PHTHALATE (BBP), DIBUTYL PHTHALATE (DBP), DIISOBUTYL PHTHALATE (DIBP).

2. MECHANICAL SPECIFICATIONS

2.1 LCD MODULE MECHANICAL SPECIFICATIONS

(1) DISPLAY SIZE	-----	12.1 inch
(2) NUMBER OF DOTS	-----	1280(BGR)W * 800H DOTS
(3) MODULE SIZE	-----	283W * 185.1H * 18.5D(MAX.) mm
(4) VIEWING AREA	-----	263.52W * 165.6H mm
(5) ACTIVE AREA	-----	261.12W * 163.2H mm
(6) DOT SIZE	-----	0.068W * 0.204H mm
(7) PIXEL SIZE	-----	0.204W * 0.204H mm
(8) LCD TYPE	-----	TFT , IPS , TRANSMISSIVE , NORMALLY BLACK
(9) COLOR	-----	16.7M
(10) VIEWING DIRECTION	-----	SUPER WIDE VIEW
(11) BACK LIGHT	-----	LED , COLOR : WHITE
(12) INTERFACE MODE	-----	HDMI 1.4
(13) WEIGHT	-----	TBD

3. ABSOLUTE MAXIMUM RATINGS

3.1 ELECTRICAL ABSOLUTE MAXIMUM RATINGS

ITEM	SYMBOL	MIN.	MAX.	UNIT	REMARK
POWER SUPPLY VOLTAGE	VDD-VSS	—	15.0	V	
STATIC ELECTRICITY	—	—	—	V	NOTE (1)

NOTE (1) : LCM SHOULD BE GROUND DURING LCM HANDLING.

NOTE (2) : THE ABSOLUTE MAXIMUM RATING VALUES OF THIS PRODUCT ARE NOT ALLOWED TO BE EXCEEDED AT ANY TIMES. SHOULD A MODULE BE USED WITH ANY OF THE ABSOLUTE MAXIMUM RATINGS EXCEEDED, THE CHARACTERISTICS OF THE MODULE MAY NOT BE RECOVERED, OR IN AN EXTREME CASE, THE MODULE MAY BE PERMANENTLY DESTROYED.

3.2 ENVIRONMENTAL ABSOLUTE MAXIMUM RATINGS

ITEM	OPERATING		STORAGE		REMARK
	MIN.	MAX.	MIN.	MAX.	
AMBIENT TEMPERATURE	-30 °C	85 °C	-40 °C	85 °C	NOTE (1),(2),(3),(4)
HUMIDITY	NOTE (3)		NOTE (3)		WITHOUT CONDENSATION
VIBRATION	—	2.45 m/s ² (0.25 G)	—	11.76 m/s ² (1.2 G)	10~100 Hz XYZ DIRECTIONS 1 HR EACH
SHOCK	—	29.4 m/s ² (3 G)	—	490.0 m/s ² (50 G)	10ms XYZ DIRECTIONS 1 TIME EACH

NOTE (1) : THE ABSOLUTE MAXIMUM RATINGS OF THIS PRODUCT SHOULD NOT BE EXCEEDED AT ANY TIME. IF THESE RATINGS ARE EXCEEDED, THE PRODUCT'S PERFORMANCE IS NOT GUARANTEED AND THE PRODUCT MAY EXPERIENCE PERMANENT DAMAGE.

NOTE (2) : BACKGROUND COLOR CHANGES SLIGHTLY DEPENDING ON AMBIENT TEMPERATURE THIS PHENOMENON IS REVERSIBLE.

NOTE (3) : Ta ≤ 60°C : 90%RH MAX. (96HRS MAX.)

Ta > 60°C : ABSOLUTE HUMIDITY MUST BE LOWER THAN THE HUMIDITY OF 90%RH AT 60°C. (96HRS MAX.)

NOTE (4) : WHEN THE LCD MODULE IS OPERATED AT A HIGHER AMBIENT TEMPERATURE THAN 60°C, THE PWM DUTY CYCLE OF THE LED BACKLIGHT SHOULD BE ADJUSTED TO BE LESS THAN (TBD)%. IF THE MODULE IS OPERATED AT A HIGHER DUTY CYCLE THAN (TBD)%, THEN THERE IS A POSSIBILITY OF DISTORTION AND IRREGULARITY OF THE PICTURE DUE TO LIQUID CRYSTAL BEHAVIOR.

4. ELECTRICAL CHARACTERISTICS

Ta = 25 °C

ITEM	SYMBOL	CONDITION	MIN.	TYP.	MAX.	UNIT	REMARK
POWER SUPPLY VOLTAGE	VDD-VSS	—	11.5	12.0	12.5	V	
POWER SUPPLY CURRENT	IDD	VDD-VSS = 12.0V	—	(TBD)	(TBD)	mA	NOTE (1)
LOGIC HIGH INPUT VOLTAGE FOR BL_EN, BL_PWM	VIH	—	1.6	—	—	V	
LOGIC LOW INPUT VOLTAGE FOR BL_EN, BL_PWM	VIL	—	—	—	0.8	V	
LED LIFE TIME	—	IF=68mA (PER LED)	50000	—	—	HRS	NOTE (4) NOTE (5)

NOTE (1) : THE DISPLAY PATTERN IS ALL “WHITE”.

NOTE (2) : INTERNAL CIRCUIT DIAGRAM OF BACKLIGHT.

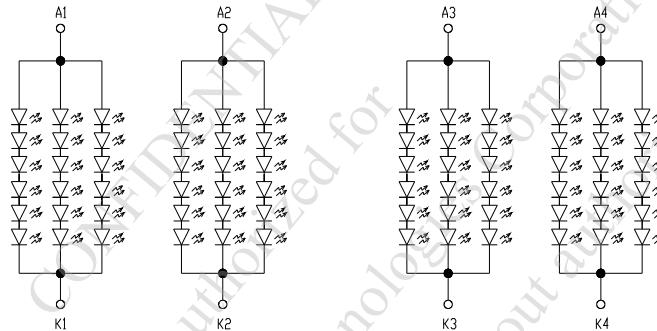

NOTE (3) : AMBIENT TEMP. VS. ALLOWABLE FORWARD CURRENT. (PER LED)

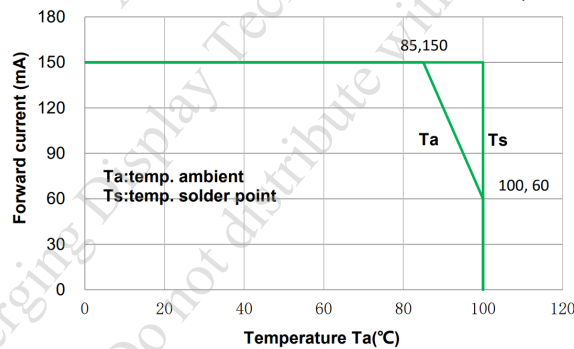

NOTE (4) : CONDITIONS; Ta=25 °C, CONTINUOUS LIGHTING

NOTE (5) : DEFINITIONS OF LIFE TIME :

LCM LUMINANCE BECOMES HALF OF THE INITIAL VALUE.

5. TIMING CHARACTERISTICS

5.1 LVDS SIGNAL TIMING CHARACTERISTICS

ITEM	SYMBOL	MIN.	TYP.	MAX.	UNIT
FRAME RATE	—	60			Hz
HORIZONTAL DISPLAY TIME	t _{HA}	1280			clock
HORIZONTAL BLANKING TIME	t _{HB}	70	80	90	clock
HORIZONTAL TOTAL TIME	t _H	1350	1360	1370	clock
VERTICAL DISPLAY TIME	t _{VA}	800			line
VERTICAL BLANKING TIME	t _{VB}	15	30	45	line
VERTICAL TOTAL TIME	t _V	815	830	845	line
CLOCK RATE	1/T _{CLOCK}	66.015	67.728	69.459	MHz

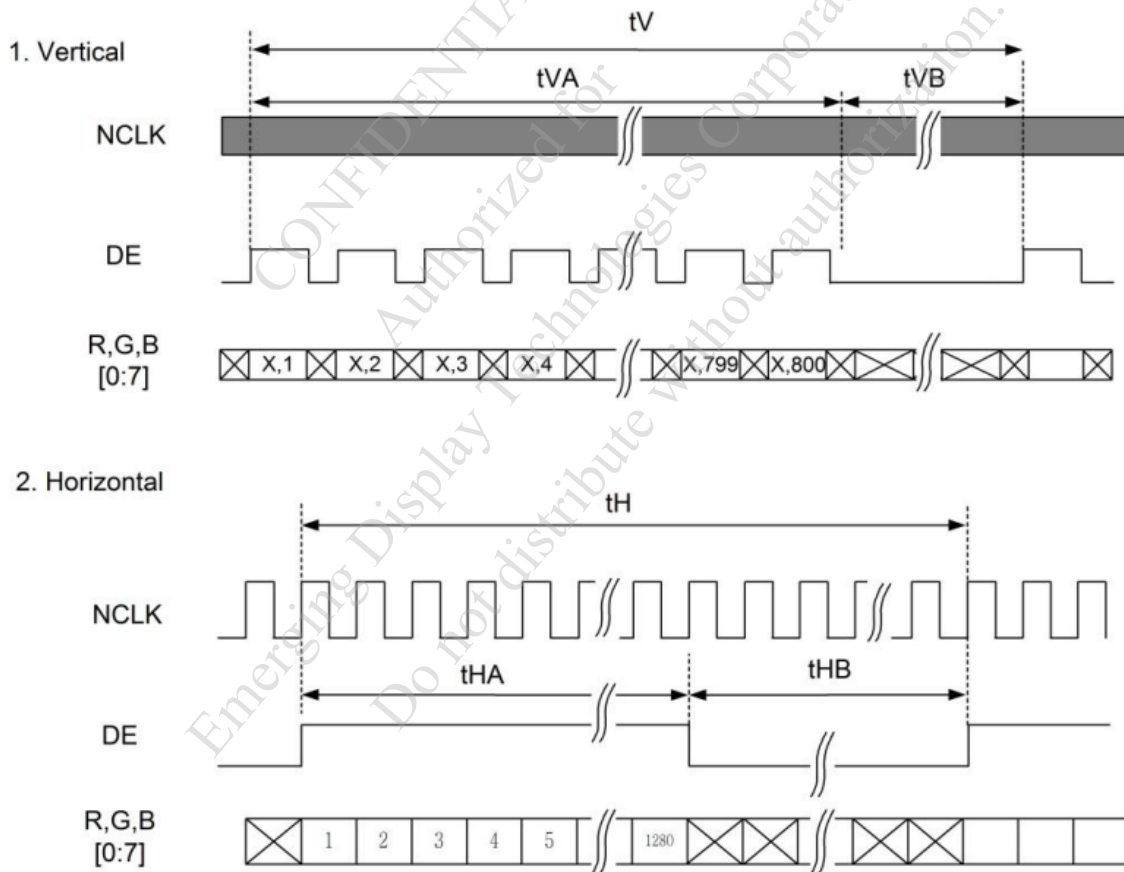

NOTE (1) : ALL TIMING PARAMETERS SHOULD BE CONSTANT IN EACH FRAME.

6. OPTICAL CHARACTERISTICS

6.1 OPTICAL CHARACTERISTICS

Ta = 25 ± 2 °C

ITEM	SYMBOL	CONDITION	MIN.	TYP.	MAX.	UNIT	REMARK	
VIEWING ANGLE	θ_{y+}	CR ≥ 10	$\theta_x=0^\circ$	80	88	—	deg.	NOTE (2) NOTE (3)
	θ_{y-}			80	88	—		
	θ_{x+}		$\theta_y=0^\circ$	80	88	—		
	θ_{x-}			80	88	—		
CONTRAST RATIO (CENTER)	CR	$\theta_x=0^\circ, \theta_y=0^\circ$	(800)	(1000)	—	—	NOTE (3)	
RESPONSE TIME	TR+TF		—	—	30	msec	NOTE (4)	
COLOR CHROMATICITY (CENTER)	WHITE	Wx	$\theta_x=0^\circ, \theta_y=0^\circ$ VDD-VSS=12.0V LED B/L=ON PWM=100%	(0.26)	(0.31)	(0.36)	—	NOTE (5)
		Wy		(0.30)	(0.35)	(0.40)		
	RED	Rx		(0.60)	(0.65)	(0.70)	—	
		Ry		(0.30)	(0.35)	(0.40)		
	GREEN	Gx		(0.28)	(0.33)	(0.38)	—	
		Gy		(0.57)	(0.62)	(0.67)		
	BLUE	Bx		(0.09)	(0.14)	(0.19)	—	
		By		(0.06)	(0.11)	(0.16)		
THE BRIGHTNESS OF MODULE (CENTER)	B		(1500)	(1600)	—	cd/m ²	NOTE (6)	
THE UNIFORMITY OF MODULE	—		70	—	—	%	NOTE (7)	

NOTE (1) : TEST CONDITION :

AFTER STABILIZING AND LEAVING THE PANEL ALONE AT A GIVEN TEMPERATURE FOR 30 MINUTES. MEASUREMENT SHOULD BE EXECUTED IN A STABLE, WINDLESS, AND DARK ROOM.

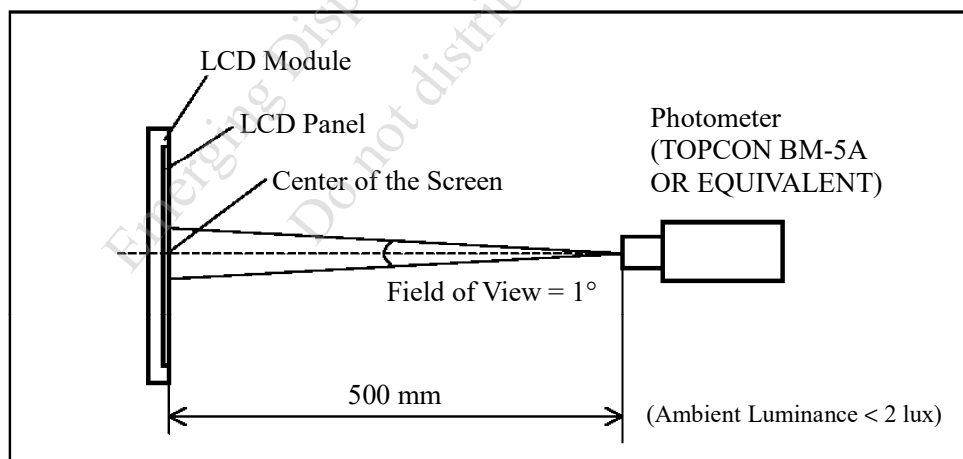

NOTE (2) : DEFINITION OF VIEWING ANGLE :

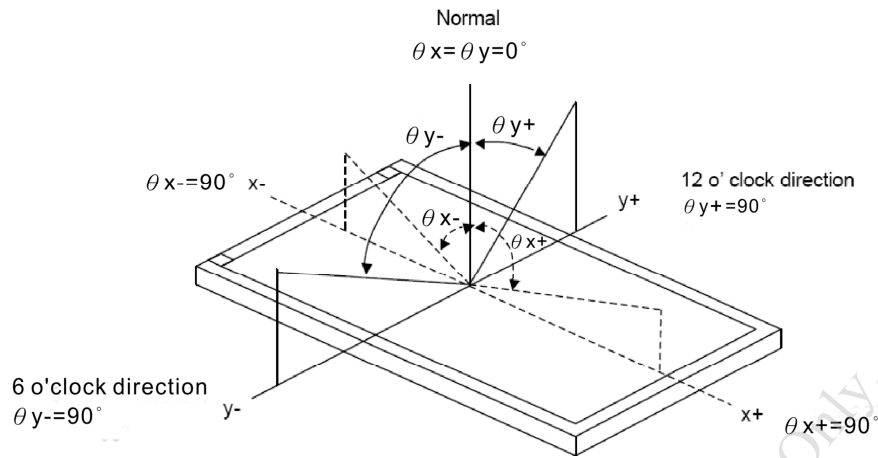

NOTE (3) : DEFINITION OF CONTRAST RATIO (CR) :
MEASURED AT THE CENTER POINT OF MODULE

$$\text{CONTRAST RATIO(CR)} = \frac{\text{BRIGHTNESS MEASURED WHEN LCD IS AT "WHITE STATE"}}{\text{BRIGHTNESS MEASURED WHEN LCD IS AT "BLACK STATE"}}$$

NOTE (4) : DEFINITION OF RESPONSE TIME : T_R AND T_F

THE FIGURE BELOW IS THE OUTPUT SIGNAL OF THE PHOTO DETECTOR.

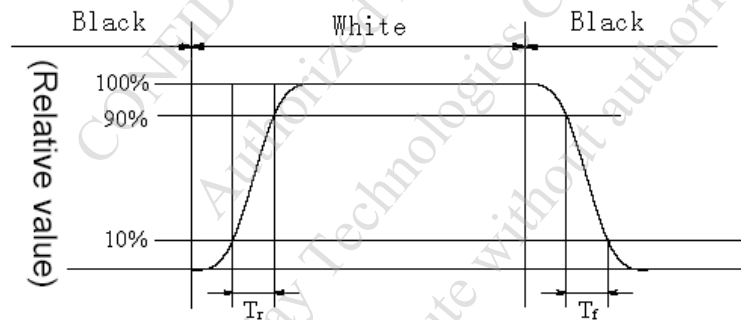

NOTE (5) : DEFINITION OF COLOR CHROMATICITY

(a) 100% RGB PIXEL DATA TRANSMISSION WHEN ALL THE INPUT TERMINALS OF MODULE ARE ELECTRICALLY POWERED ON.

(b) MEASURED AT THE CENTER POINT OF MODULE

NOTE (6) : MEASURED THE BRIGHTNESS OF WHITE STATE AT CENTER POINT.

NOTE (7) : (a) DEFINITION OF BRIGHTNESS UNIFORMITY

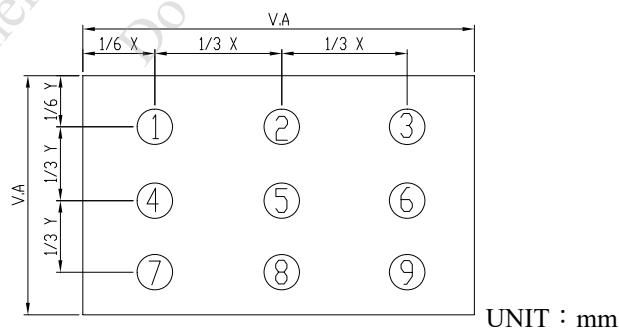

(b) THE BRIGHTNESS UNIFORMITY CALCULATING METHOD

$$\text{UNIFORMITY} : \frac{\text{MINIMUM BRIGHTNESS}}{\text{MAXIMUM BRIGHTNESS}} * 100\%$$

7. OUTLINE DIMENSIONS

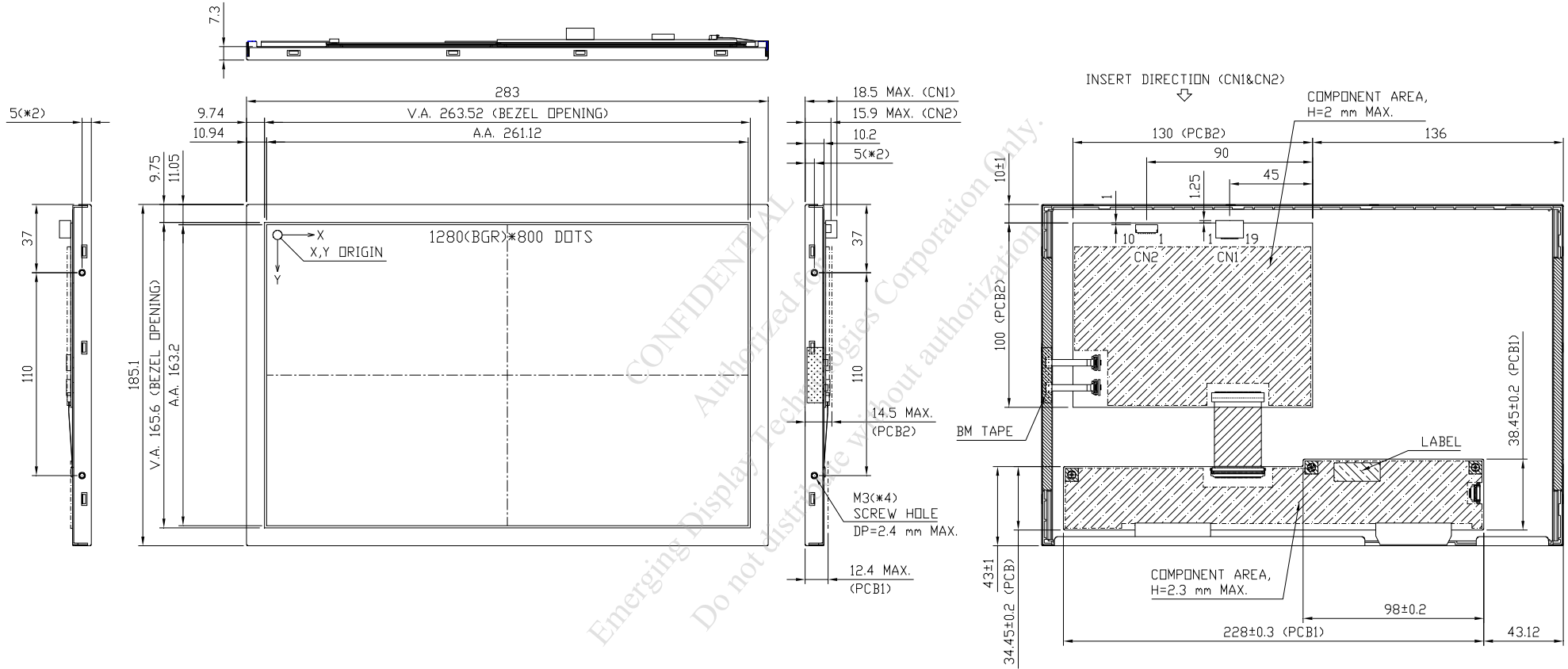

UNIT : mm
SCALE : NTS

THIRD ANGLE PROJECTION

NOT SPECIFIED TOLERANCE IS ±0.5

NOTE :

- 1.CN1(HDMI) : TOKUTSU HHF-14A000-2SE OR EQUIVALENT.
- 2.CN2(B/L) : JST SM10B-SRSS-TB OR EQUIVALENT.

8. BLOCK DIAGRAM

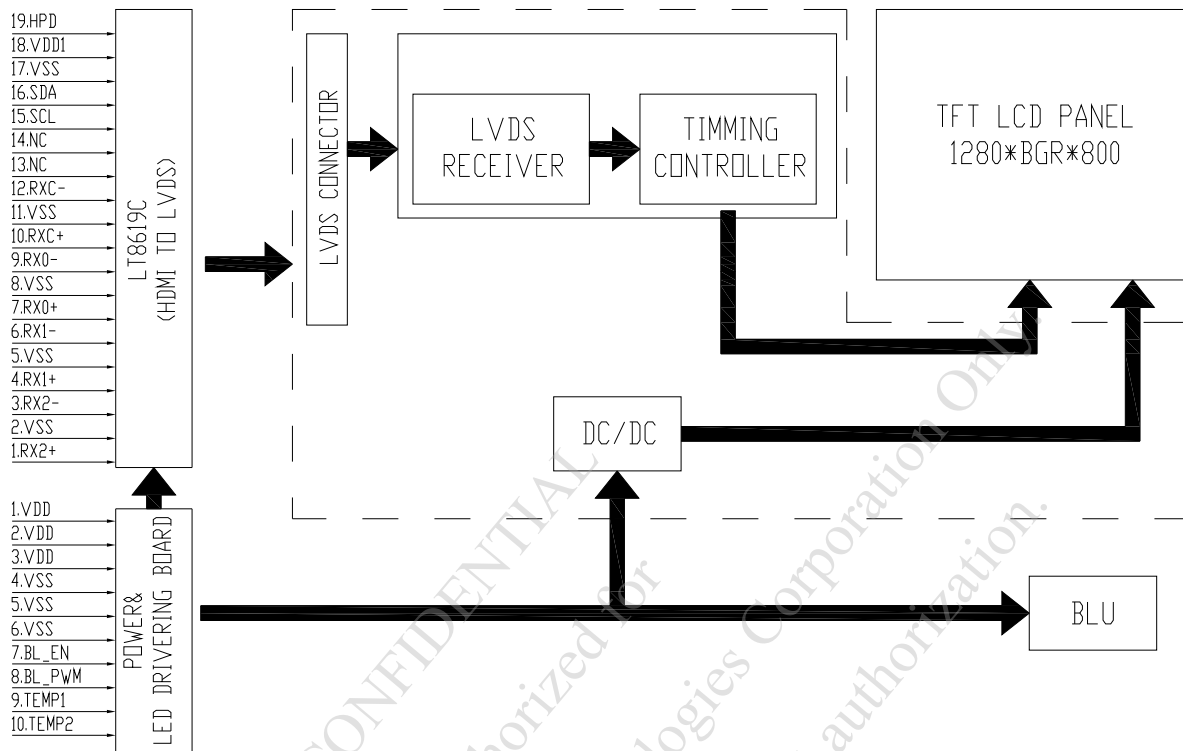

CONFIDENTIAL
 Authorized for
 Emerging Display Technologies Corporation Only.
 Do not distribute without authorization.

9. DETAIL DRAWING OF DOT MATRIX

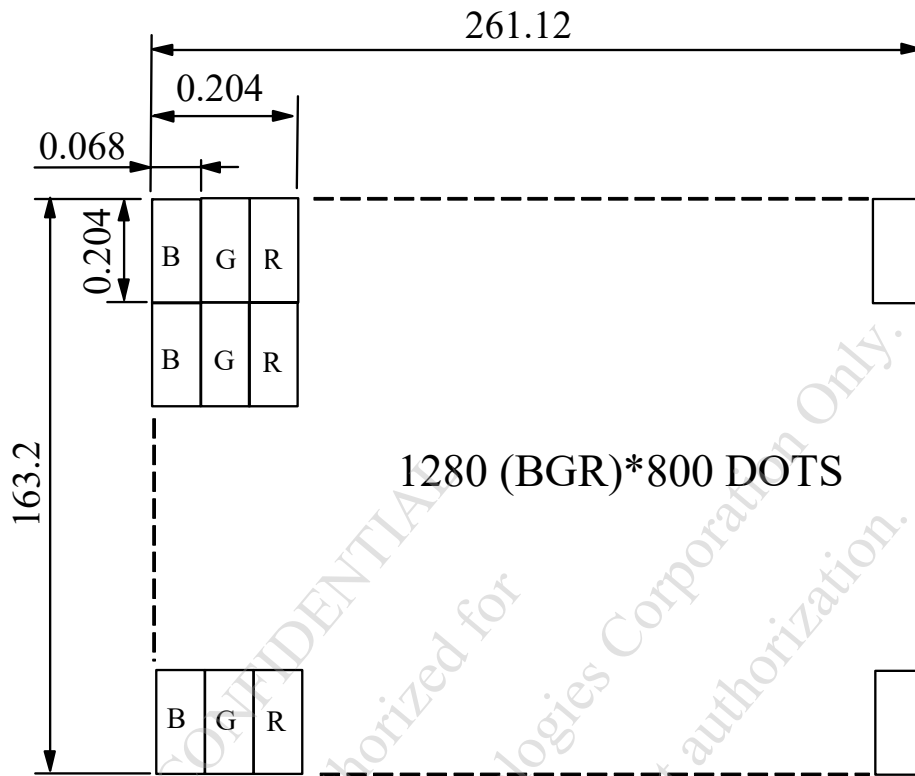

UNIT : mm

SCALE : NTS

NOT SPECIFIED TOLERANCE IS ± 0.1

DOTS MATRIX TOLERANCE IS ± 0.01

CONFIDENTIAL
Authorized for Emerging Display Technologies Corporation Only.
Do not distribute without authorization.

10. INTERFACE SIGNALS

10.1 CN1(HDMI)

PIN NO.	SYMBOL	FUNCTION
1	RX2+	TMDS CHANNEL 2 DATA+
2	VSS	GROUND
3	RX2-	TMDS CHANNEL 2 DATA-
4	RX1+	TMDS CHANNEL 1 DATA+
5	VSS	GROUND
6	RX1-	TMDS CHANNEL 1 DATA-
7	RX0+	TMDS CHANNEL 0 DATA+
8	VSS	GROUND
9	RX0-	TMDS CHANNEL 0 DATA-
10	RXC+	TMDS CLOCK+
11	VSS	GROUND
12	RXC-	TMDS CLOCK-
13	NC	NON CONNECTION
14	NC	NON CONNECTION
15	SCL	DDC CLOCK
16	SDA	DDC DATA
17	VSS	GROUND
18	VDD1	POWER SUPPLY VOLTAGE FOR HDMI
19	HPD	HOT PLUG DETECT

10.2 CN2 (POWER&LED BACKLIGHT)

PIN NO.	SYMBOL	FUNCTION
1	VDD	POWER SUPPLY VOLTAGE
2	VDD	POWER SUPPLY VOLTAGE
3	VDD	POWER SUPPLY VOLTAGE
4	VSS	GROUND
5	VSS	GROUND
6	VSS	GROUND
7	BL_EN	BACKLIGHT LED ON/OFF CONTROL
8	BL_PWM	BACKLIGHT LED BRIGHTNESS CONTROL
9	TEMP1	TEMPERATURE SENSOR PIN1
10	TEMP2	TEMPERATURE SENSOR PIN2

NOTE (1) : TEMP1, TEMP2

THERMISTOR CHARACTERISTICS(EDT MATERIAL : TH20-3H103FT)

ITEM	SPECIFICATION	CONDITION
RESISTANCE	10K OHM \pm 1%	ZERO-POWER RESISTANCE AT 25°C
B-CONSTANT	3370K \pm 1%	B-VALUE BETWEEN 25 TO 50°C
MAXIMUM POWER DISSIPATION	500mW	AT 25°C
HEAT DISSIPATION	5.0mW/°C	
OPERATING TEMPERATURE RANGE	-40°C~125°C	
RoHS	COMPLIANT	

11. POWER SUPPLY

11.1 POWER SUPPLY FOR LCM

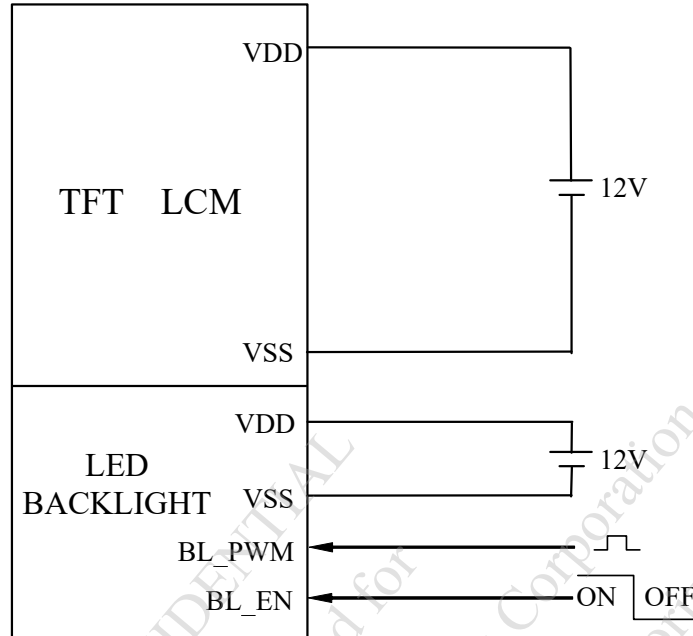

NOTE (1) : ADJUST THE PWM SIGNAL IN ORDER TO CONTROL LED BACKLIGHT'S BRIGHTNESS. THE HIGHER THE DUTY CYCLE, THE HIGHER THE BRIGHTNESS

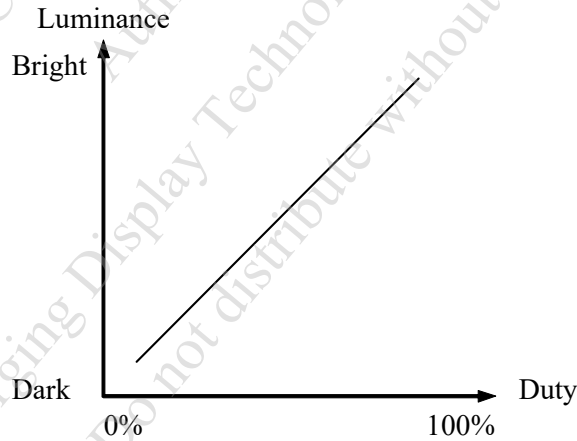

NOTE (2) : PWM SIGNAL OPERATION FREQUENCY IS 100~2000Hz AND DIMMING DUTY.

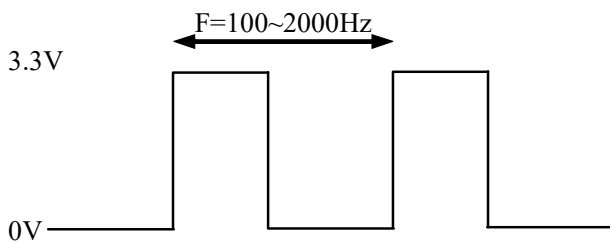

PWM Dimming Frequency[Hz]	Dimming Duty	
	Min[%]	Max[%]
$100 < F_{DIM} < 200$	0.1	100
$200 < F_{DIM} < 500$	0.4	100
$200 < F_{DIM} < 1K$	0.8	100
$1K < F_{DIM} < 2K$	1.5	100

12. INSPECTION CRITERIA

12.1 APPLICATION

THIS INSPECTION STANDARD IS TO BE APPLIED TO THE LCD MODULE DELIVERED FROM EMERGING DISPLAY TECHNOLOGIES CORP.(E.D.T) TO CUSTOMERS

12.2 INSPECTION CONDITIONS

12.2.1 (1)OBSERVATION DISTANCE : 45 ± 5 cm

(2)VIEWING ANGLE : $\pm 45^\circ$

$\pm 45^\circ$ (FOR SECTION WITHIN VIEWING AREA), REFER TO FIG.A
 90° (FOR SECTION OUTSIDE OF VIEWING AREA), REF TO FIG.B
PERPENDICULAR TO MODULE SURFACE

VIEWING ANGLE SHOULD BE SMALLER THAN 45°

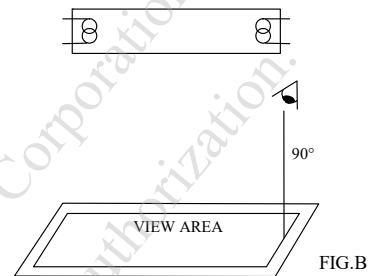
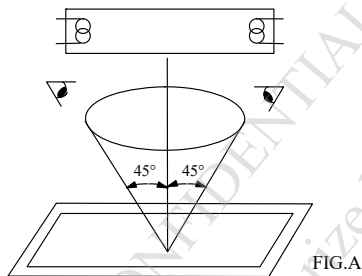

THE INSPECTION CRITERIA IS ACCORDING TO LINE OF SIGHT. INSPECTION SHALL BE MADE WITHIN THE HALF SECTION OF THE VIEWING CONE GENERATED BY LINE SEGMENT OF 45° WITH RESPECT TO THE VERTICAL AXIS FROM CENTER VERTEX OF LCD, THE FLUORESCENT LAMP AND THE CONE AXIS MUST BE PERPENDICULAR TO THE LCD SURFACE.

IF THE DEFECTS ARE OUTSIDE OF VIEWING AREA, IT SHALL BE INSPECTED BY 90° WITH RESPECT TO THE VERTICAL AXIS FROM EDGE OF VIEWING AREA.

12.2.2 ENVIRONMENT CONDITIONS :

AMBIENT TEMPERATURE		$25 \pm 5^\circ\text{C}$
AMBIENT HUMIDITY		$65 \pm 20\%RH$
AMBIENT ILLUMINATION	COSMETIC INSPECTION	600~800 lux
	FUNCTIONAL INSPECTION	300~500 lux
INSPECTION TIME		15 secs

12.2.3 INSPECTION LOT

QUANTITY PER DELIVERY LOT FOR EACH MODEL

12.2.4 INSPECTION METHOD

A SAMPLING INSPECTION SHALL BE MADE ACCORDING TO THE FOLLOWING PROVISIONS TO JUDGE THE ACCEPTABILITY

(a)APPLICABLE STANDARD :

ANSI/ ASQ Z1.4 NORMAL INSPECTION LEVEL II

(b)AQL : MAJOR DEFECT : AQL 0.65

MINOR DEFECT : AQL 1.0

12.3 INSPECTION STANDARDS

12.3.1 VISUAL DEFECTS CLASSIFICATION

TYPE OF DEFECT	INSPECTION ITEM	DEFECT FEATURE	AQL
MAJOR DEFECT	1.DISPLAY ON	<ul style="list-style-type: none"> • DEFECT TO MISS SPECIFIED DISPLAY FUNCTION, FOR ALL AND SPECIFIED DOTS EX: DISCONNECTION, SHORT CIRCUIT ETC 	0.65
	2.BACKLIGHT	<ul style="list-style-type: none"> • NO LIGHT • FLICKERING AND OTHER ABNORMAL ILLUMINATION 	
	3.DIMENSIONS	<ul style="list-style-type: none"> • SUBJECT TO INDIVIDUAL ACCEPTANCE SPECIFICATIONS 	
MINOR DEFECT	1.DISPLAY ZONE	<ul style="list-style-type: none"> • BLACK/WHITE SPOT • BUBBLES ON POLARIZER • NEWTON RING • BLACK/WHITE LINE • SCRATCH • CONTAMINATION • LEVER COLOR SPREAD 	1.0
	2.BEZEL ZONE	<ul style="list-style-type: none"> • STAINS • SCRATCHES • FOREIGN MATTER 	
	3.SOLDERING	<ul style="list-style-type: none"> • INSUFFICIENT SOLDER • SOLDERED IN INCORRECT POSITION • CONVEX SOLDERING SPOT • SOLDER BALLS • SOLDER SCRAPS 	
	4.DISPLAY ON (ALL ON)	<ul style="list-style-type: none"> • LIGHT LINE 	

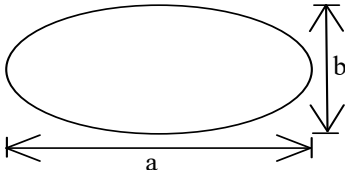

12.3.2 MODULE DEFECTS CLASSIFICATION

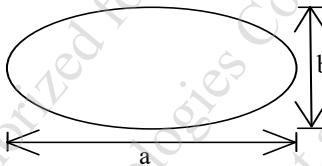
NO.	ITEM	CRITERIA												
1	DISPLAY ON INSPECTION	1. INCORRECT PATTERN 2. MISSING SEGMENT 3. DIM SEGMENT 4. OPERATING VOLTAGE BEYOND SPEC												
2	OVERALL DIMENSIONS	1. OVERALL DIMENSION BEYOND SPEC												
3	DOT DEFECT	<p>1. INSPECTION PATTERN: FULL WHITE, FULL BLACK, RED, GREEN AND BLUE SCREENS.</p> <p>2.</p> <table border="1"> <thead> <tr> <th>ITEMS</th> <th>ACCEPTABLE COUNT</th> </tr> </thead> <tbody> <tr> <td>BRIGHT DOT</td> <td>$N \leq 1$</td> </tr> <tr> <td>DARK DOT</td> <td>$N \leq 4$</td> </tr> <tr> <td>TOTAL BRIGHT AND DARK DOTS</td> <td>$N \leq 4$</td> </tr> </tbody> </table> <p>NOTE :</p> <p>(1)THE DEFINITION OF DOT : THE SIZE OF A DEFECTIVE DOT OVER 1/2 OF WHOLE DOT IS REGARDED AS ONE DEFECTIVE DOT.</p> <p>(2)BRIGHT DOT : DOTS APPEAR BRIGHT AND UNCHANGED IN SIZE IN WHICH LCD PANEL IS DISPLAYING UNDER BLACK PATTERN. THE BRIGHT DOT DEFECT MUST BE VISIBLE THROUGH 5% ND FILTER.</p> <p>(3)DARK DOT : DOTS APPEAR DARK AND UNCHANGED IN SIZE IN WHICH LCD PANEL IS DISPLAYING UNDER PURE RED, GREEN, BLUE PICTURE.</p>	ITEMS	ACCEPTABLE COUNT	BRIGHT DOT	$N \leq 1$	DARK DOT	$N \leq 4$	TOTAL BRIGHT AND DARK DOTS	$N \leq 4$				
ITEMS	ACCEPTABLE COUNT													
BRIGHT DOT	$N \leq 1$													
DARK DOT	$N \leq 4$													
TOTAL BRIGHT AND DARK DOTS	$N \leq 4$													
4	FOREIGN BLACK/WHITE/ BRIGHT LINE/ OF VIEWING AREA	<table border="1"> <thead> <tr> <th>LENGTH : L</th> <th>WIDTH : W</th> <th>PERMISSIBLE NO.</th> </tr> </thead> <tbody> <tr> <td>—</td> <td>$W \leq 0.05$</td> <td>IGNORE</td> </tr> <tr> <td>$0.3 < L \leq 1.0$</td> <td>$0.05 < W \leq 0.1$</td> <td>4</td> </tr> <tr> <td>$1.0 < L$</td> <td>$0.1 < W$</td> <td>NONE</td> </tr> </tbody> </table> <p>WIDTH : W mm, LENGTH : L mm</p>	LENGTH : L	WIDTH : W	PERMISSIBLE NO.	—	$W \leq 0.05$	IGNORE	$0.3 < L \leq 1.0$	$0.05 < W \leq 0.1$	4	$1.0 < L$	$0.1 < W$	NONE
LENGTH : L	WIDTH : W	PERMISSIBLE NO.												
—	$W \leq 0.05$	IGNORE												
$0.3 < L \leq 1.0$	$0.05 < W \leq 0.1$	4												
$1.0 < L$	$0.1 < W$	NONE												
5	POLARIZER SCRATCHES	<table border="1"> <thead> <tr> <th>LENGTH : L</th> <th>WIDTH : W</th> <th>PERMISSIBLE NO.</th> </tr> </thead> <tbody> <tr> <td>—</td> <td>$W \leq 0.05$</td> <td>IGNORE</td> </tr> <tr> <td>$1.0 < L \leq 5.0$</td> <td>$0.05 < W \leq 0.2$</td> <td>4</td> </tr> <tr> <td>$5.0 < L$</td> <td>$0.2 < W$</td> <td>NONE</td> </tr> </tbody> </table> <p>WIDTH : W mm, LENGTH : L mm</p>	LENGTH : L	WIDTH : W	PERMISSIBLE NO.	—	$W \leq 0.05$	IGNORE	$1.0 < L \leq 5.0$	$0.05 < W \leq 0.2$	4	$5.0 < L$	$0.2 < W$	NONE
LENGTH : L	WIDTH : W	PERMISSIBLE NO.												
—	$W \leq 0.05$	IGNORE												
$1.0 < L \leq 5.0$	$0.05 < W \leq 0.2$	4												
$5.0 < L$	$0.2 < W$	NONE												
6	FOREIGN MATTER \ BLACK SPOTS \ WHITE SPOTS \ DENT (INCLUDING LIGHT LEAKAGE DUE TO POLARIZING PLATES PINHOLES, ETC.)	<table border="1"> <thead> <tr> <th>AVERAGE DIAMETER (mm): D</th> <th>NUMBER OF PIECES PERMITTED</th> </tr> </thead> <tbody> <tr> <td>$D \leq 0.15$</td> <td>IGNORE</td> </tr> <tr> <td>$0.15 < D \leq 0.5$</td> <td>5</td> </tr> <tr> <td>$0.5 < D$</td> <td>NONE</td> </tr> </tbody> </table> <p>NOTE : DIAMETER $D=(a+b)/2$</p> 	AVERAGE DIAMETER (mm): D	NUMBER OF PIECES PERMITTED	$D \leq 0.15$	IGNORE	$0.15 < D \leq 0.5$	5	$0.5 < D$	NONE				
AVERAGE DIAMETER (mm): D	NUMBER OF PIECES PERMITTED													
$D \leq 0.15$	IGNORE													
$0.15 < D \leq 0.5$	5													
$0.5 < D$	NONE													

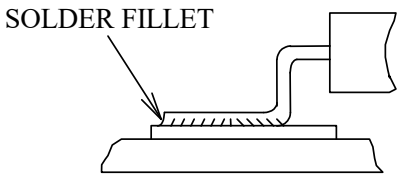
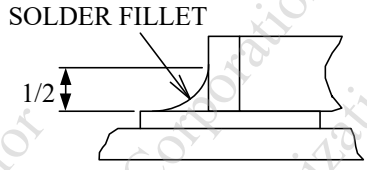
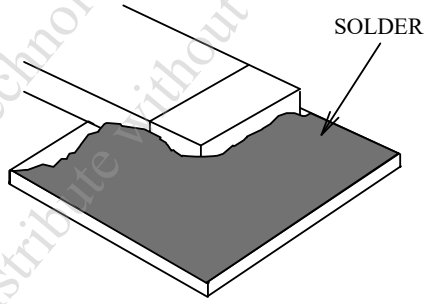
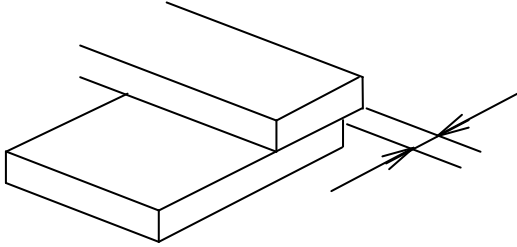
NO.	ITEM	CRITERIA		
			AVERAGE DIAMETER (mm) : D	NUMBER OF PIECES PERMITTED
7	BUBBLES OF POLARIZER / DIRT / CF FAIL / SURFACE STAINS	BUBBLE ON THE POLARIZER	$D \leq 0.25$	IGNORE
			$0.25 < D \leq 0.5$	$N \leq 5$
			$0.5 < D$	NONE
		SURFACE STAINS	$D \leq 0.15$	IGNORE
			$0.15 < D \leq 0.5$	$N \leq 4$
			$0.5 < D$	NONE
		CF FAIL / SPOT	$D \leq 0.25$	IGNORE
			$0.25 < D \leq 0.5$	$N \leq 4$
			$0.5 < D$	NONE
		<p>NOTE : (1)POLARIZER BUBBLE IS DEFINED AS THE BUBBLE APPEARS ON ACTIVE DISPLAY AREA. THE DEFECT OF POLARIZER BUBBLE SHALL BE IGNORED IF THE POLARIZER BUBBLE APPEARS ON THE OUTSIDE OF ACTIVE DISPLAY AREA.</p> <p>(2)THE EXTRANEOUS SUBSTANCE IS DEFINED AS IT CAN BE OBSERVED WHEN THE MODULE IS POWER ON.</p> <p>(3)THE DEFINITION OF AVERAGE DIAMETER, D IS DEFINED AS FOLLOWING.</p> <p>AVERAGE DIAMETER (D)=(a+b)/2</p> 		
8	LINE DEFECT ON DISPLAY	OBVIOUS VERTICAL OR HORIZONTAL LINE DEFECT IS NOT ALLOWED		
9	MURA ON DISPLAY	NOT VISIBLE THROUGH 5% ND FILTER OR JUDGED BY LIMIT SAMPLE IF NECESSARY.		
10	UNEVEN COLOR SPREAD, COLORATION	1. TO BE DETERMINED BASED UPON THE STANDARD SAMPLE.		
11	BEZEL APPEARANCE	<p>1. BEZEL MAY NOT HAVE RUST, BE DEFORMED OR HAVE FINGER PRINTS STAINS OF OTHER CONTAMINATION.</p> <p>2. BEZEL MUST COMPLY WITH JOB SPECIFICATIONS.</p>		
12	PCB	<p>1. THERE MAY NOT BE MORE THAN 2mm OF SEALANT OUTSIDE THE SEAL AREA ON THE PCB, AND THERE SHOULD BE NO MORE THAN THREE PLACES.</p> <p>2. NO OXIDATION OR CONTAMINATION PCB TERMINALS.</p> <p>3. PARTS ON PCB MUST BE THE SAME AS ON THE PRODUCTION CHARACTERISTIC CHART. THERE SHOULD BE NO WRONG PARTS, MISSING PARTS OR EXCESS PARTS.</p> <p>4. THE JUMPER ON THE PCB SHOULD CONFORM TO THE PRODUCT CHARACTERISTIC CHART.</p> <p>5. IF SOLDER GETS ON BEZEL TAB PADS, LED PAD, ZEBRA PAD OR SCREW HOLD PAD; MAKE SURE IT IS SMOOTHED DOWN.</p>		

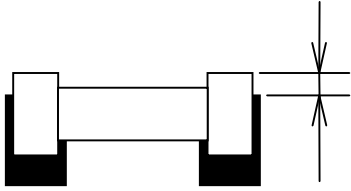
NO.	ITEM	CRITERIA
13	SOLDERING	<p>1. NO SOLDERING FOUND ON THE SPECIFIED PLACE</p> <p>2. INSUFFICIENT SOLDER</p> <p>(a) LSI, IC A POOR WETTING OF SOLDER IS BETWEEN LOWER BEND OR "HEEL" OF LEAD AND PAD</p>  <p>(b) CHIP COMPONENT</p> <ul style="list-style-type: none"> SOLDER IS LESS THAN 50% OF SIDES AND FRONT FACE WETTING  <ul style="list-style-type: none"> SOLDER WETS 3 SIDES OF TERMINAL, BUT LESS THAN 25% OF SIDES AND FRONT SURFACE AREA ARE COVERED  <p>3. PARTS ALIGMENT</p> <p>(a) LSI, IC LEAD WIDTH IS MORE THAN 50% BEYOND PAD OUTLINE</p> 

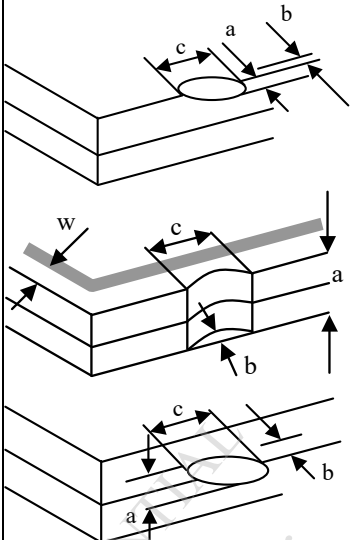
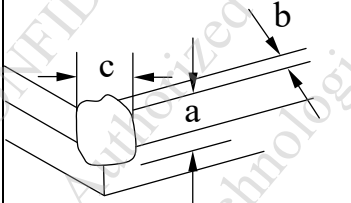
NO.	ITEM	CRITERIA
13	SOLDERING	<p>(b)CHIP COMPONENT COMPONENT IS OFF CENTER, AND MORE THAN 50% OF THE LEADS IS OFF THE PAD OUTLINE</p>  <p>4. NO UNMELTED SOLDER PASTE MAY BE PRESENT ON THE PCB. 5. NO COLD SOLDER JOINTS, MISSING SOLDER CONNECTIONS, OXIDATION OR ICICLE. 6. NO RESIDUE OR SOLDER BALLS ON PCB. 7. NO SHORT CIRCUITS IN COMPONENTS ON PCB.</p>
14	BACKLIGHT	<p>1. NO LIGHT 2. FLICKERING AND OTHER ABNORMAL ILLUMINATION 3. SPOTS OR SCRATCHES THAT APPEAR WHEN LIT MUST BE JUDGED USING LCD SPOT, LINES AND CONTAMINATION STANDARDS. 4. BACKLIGHT DOESN'T LIGHT OR COLOR IS WRONG.</p>
15	GENERAL APPEARANCE	<p>1. NO OXIDATION, CONTAMINATION, CURVES OR, BENDS ON INTERFACE PIN (OLB) OF TCP. 2. NO CRACKS ON INTERFACE PIN (OLB) OF TCP. 3. NO CONTAMINATION, SOLDER RESIDUE OR SOLDER BALLS ON PRODUCT. 4. THE IC ON THE TCP MAY NOT BE DAMAGED, CIRCUITS. 5. THE UPPERMOST EDGE OF THE PROTECTIVE STRIP ON THE INTERFACE PIN MUST BE PRESENT OR LOOK AS IF IT CAUSE THE INTERFACE PIN TO SEVER. 6. THE RESIDUAL ROSIN OR TIN OIL OF SOLDERING (COMPONENT OR CHIP COMPONENT) IS NOT BURNED INTO BROWN OR BLACK COLOR. 7. SEALANT ON TOP OF THE ITO CIRCUIT HAS NOT HARDENED. 8. PIN TYPE MUST MATCH TYPE IN SPECIFICATION SHEET. 9. LCD PIN LOOSE OR MISSING PINS. 10. PRODUCT PACKAGING MUST THE SAME AS SPECIFIED ON PACKAGING SPECIFICATION SHEET. 11. PRODUCT DIMENSION AND STRUCTURE MUST CONFORM TO PRODUCT SPECIFICATION SHEET. 12. THE APPEARANCE OF HEAT SEAL SHOULD NOT ADMIT ANY DIRT AND BREAK.</p>

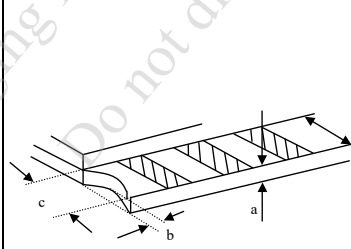
NO.	ITEM	CRITERIA									
16	CRACKED GLASS	<p>THE LCD WITH EXTENSIVE CRACK IS NOT ACCEPTABLE</p> <p>GENERAL GLASS CHIP :</p>  <table border="1"> <thead> <tr> <th>a</th> <th>b</th> <th>c</th> </tr> </thead> <tbody> <tr> <td>$\leq t/2$</td> <td>< VIEWING AREA</td> <td>$\leq 1/8X$</td> </tr> <tr> <td>$t/2 > , \leq 2t$</td> <td>$\leq W/2$</td> <td>$\leq 1/8X$</td> </tr> </tbody> </table> <p>*W=DISTANCE BETWEEN SEALANT AREA AND LCD PANEL EDGE X = LCD SIDE LENGTH t = GLASS THICKNESS</p>	a	b	c	$\leq t/2$	< VIEWING AREA	$\leq 1/8X$	$t/2 > , \leq 2t$	$\leq W/2$	$\leq 1/8X$
		a	b	c							
		$\leq t/2$	< VIEWING AREA	$\leq 1/8X$							
		$t/2 > , \leq 2t$	$\leq W/2$	$\leq 1/8X$							
<p>CORNER PART :</p>  <table border="1"> <thead> <tr> <th>a</th> <th>b</th> <th>c</th> </tr> </thead> <tbody> <tr> <td>$\leq t/2$</td> <td>< VIEWING AREA</td> <td>$\leq 1/8X$</td> </tr> <tr> <td>$> t/2 , \leq 2t$</td> <td>$\leq W/2$</td> <td>$\leq 1/8X$</td> </tr> </tbody> </table> <p>*W=DISTANCE BETWEEN SEALANT AREA AND LCD PANEL EDGE X = LCD SIDE LENGTH t = GLASS THICKNESS</p>	a	b	c	$\leq t/2$	< VIEWING AREA	$\leq 1/8X$	$> t/2 , \leq 2t$	$\leq W/2$	$\leq 1/8X$		
a	b	c									
$\leq t/2$	< VIEWING AREA	$\leq 1/8X$									
$> t/2 , \leq 2t$	$\leq W/2$	$\leq 1/8X$									
<p>CHIP ON ELECTRODE PAD</p>  <table border="1"> <thead> <tr> <th>a</th> <th>b</th> <th>c</th> </tr> </thead> <tbody> <tr> <td>$\leq t$</td> <td>$\leq 0.5\text{mm}$</td> <td>$\leq 1/8X$</td> </tr> </tbody> </table> <p>* X=LCD SIDE WIDTH t =GLASS THICKNESS</p>	a	b	c	$\leq t$	$\leq 0.5\text{mm}$	$\leq 1/8X$					
a	b	c									
$\leq t$	$\leq 0.5\text{mm}$	$\leq 1/8X$									
 <table border="1"> <thead> <tr> <th>a</th> <th>b</th> <th>c</th> </tr> </thead> <tbody> <tr> <td>$\leq t$</td> <td>$\leq 1/8X$</td> <td>$\leq L$</td> </tr> </tbody> </table> <p>*X=LCD SIDE WIDTH t = GLASS THICKNESS L=ELECTRODE PAD LENGTH</p> <p>①IF GLASS CHIPPING THE ITO TERMINAL, OVER 2/3 OF THE ITO MUST REMAIN AND BE, INSPECTED ACCORDING TO ELECTRODE TERMINAL SPECIFICATIONS</p> <p>②IF THE PRODUCT WILL BE HEAT SEALED BY THE CUSTOMER, THE ALIGNMENT MARK MUST NOT BE DAMAGED</p>	a	b	c	$\leq t$	$\leq 1/8X$	$\leq L$					
a	b	c									
$\leq t$	$\leq 1/8X$	$\leq L$									

13. RELIABILITY TEST

13.1 STANDARD SPECIFICATIONS FOR RELIABILITY OF LCD MODULE

NO.	ITEM	DESCRIPTION
1	HIGH TEMPERATURE TEST (OPERATION)	THE SAMPLE SHOULD BE ALLOWED TO STAND AT +85°C FOR 240 HRS
2	LOW TEMPERATURE TEST (OPERATION)	THE SAMPLE SHOULD BE ALLOWED TO STAND AT -30°C FOR 240 HRS
3	HIGH TEMPERATURE TEST (STORAGE)	THE SAMPLE SHOULD BE ALLOWED TO STAND AT +85°C FOR 240 HRS
4	LOW TEMPERATURE TEST (STORAGE)	THE SAMPLE SHOULD BE ALLOWED TO STAND AT -40°C FOR 240 HRS
5	HIGH TEMPERATURE /HUMIDITY TEST TEST (STORAGE)	THE SAMPLE SHOULD BE ALLOWED TO STAND AT 60°C, 90% RH 240 HRS
6	THERMAL SHOCK (NOT OPERATED)	<p>THE SAMPLE SHOULD BE ALLOWED TO STAND THE FOLLOWING 10 CYCLES OF OPERATION:</p>
7	ESD (ELECTROSTATIC DISCHARGE) (NOT OPERATED)	AIR DISCHARGE ± 12KV CONTACT DISCHARGE ± 8KV (ACCORDING TO IEC-61000-4-2)

NOTE (1) : THE TEST SAMPLES HAVE RECOVERY TIME FOR 2 HOURS AT ROOM TEMPERATURE BEFORE THE FUNCTION CHECK. IN THE STANDARD CONDITIONS, THERE IS NO DISPLAY FUNCTION NG ISSUE OCCURRED.

NOTE (2) : WHEN THE LCD MODULE IS OPERATED AT A HIGHER AMBIENT TEMPERATURE THAN 60°C, THE PWM DUTY CYCLE OF THE LED BACKLIGHT SHOULD BE ADJUSTED TO BE LESS THAN (TBD)%. IF THE MODULE IS OPERATED AT A HIGHER DUTY CYCLE THAN (TBD)%, THEN THERE IS A POSSIBILITY OF DISTORTION AND IRREGULARITY OF THE PICTURE DUE TO LIQUID CRYSTAL BEHAVIOR.

NOTE (3) : TESTING CONDITIONS AND INSPECTION CRITERIA

NO.	ITEM	TEST MODEL	INSPECTION CRITERIA
1	CURRENT CONSUMPTION	REFER TO SPECIFICATION	THE CURRENT CONSUMPTION SHOULD CONFORM TO THE PRODUCT SPECIFICATION.
2	CONTRAST	REFER TO SPECIFICATION	AFTER THE TESTS HAVE BEEN EXECUTED, THE CONTRAST MUST BE LARGER THAN HALF OF ITS INITIAL VALUE PRIOR TO THE TESTS.
3	APPEARANCE	VISUAL INSPECTION	DEFECT FREE

14. CAUTION

14.1 OPERATION

- 14.1.1 DO NOT CONNECT OR DISCONNECT MODULES TO OR FROM THE MAIN SYSTEM WHILE POWER IS BEING SUPPLIED .
- 14.1.2 USE THE MODULE WITHIN SPECIFIED TEMPERATURE ; LOWER TEMPERATURE CAUSES THE RETARDATION OF BLINKING SPEED OF THE DISPLAY ; HIGHER TEMPERATURE MAKES OVERALL DISPLAY DISCOLOR . WHEN THE TEMPERATURE RETURNS TO NORMALITY, THE DISPLAY WILL OPERATE NORMALLY.
- 14.1.3 ADJUST THE LC DRIVING VOLTAGE TO OBTAIN THE OPTIMUM CONTRAST .
- 14.1.4 POWER ON SEQUENCE INPUT SIGNALS SHOULD NOT BE SUPPLIED TO LCD MODULE BEFORE POWER SUPPLY VOLTAGE IS APPLIED AND REACHES THE SPECIFIED VALUE.
IF ABOVE SEQUENCE IS NOT FOLLOWED , CMOS LSIS OF LCD MODULES MAY BE DAMAGED DUE TO LATCH - UP PROBLEM.
- 14.1.5 NOT ALLOWED TO INFLICT ANY EXTERNAL STRESS AND TO CAUSE ANY MECHANICAL INTERFERENCE ON THE BENDING AREA OF FPC DURING THE TAIL BENDING BACKWARDS!
DO NOT STRESS FPC AND IC ON THE MODULE!

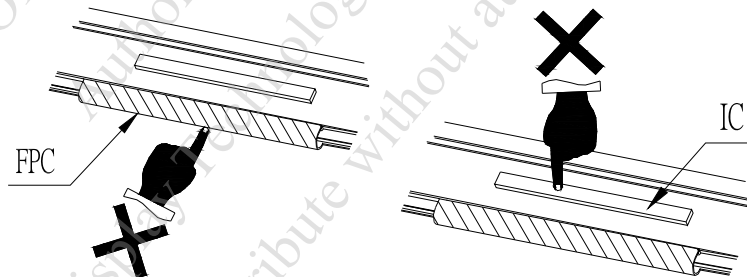

14.2 HANDLING

- 14.2.1 USE A GROUNDED SOLDERING IRON WHEN SOLDERING CONNECTOR I/O TERMINALS . FOR SOLDERING OR REPAIRING, TAKE PRECAUTION AGAINST THE TEMPERATURE OF THE SOLDERING IRON AND THE SOLDERING TIME TO PREVENT PEELING OFF THE THROUGH-HOLE-PAD.
- 14.2.2 DO NOT DISASSEMBLE . EDT SHALL NOT BE HELD RESPONSIBLE IF THE MODULE IS DISASSEMBLED AND UPON THE REASSEMBLY THE MODULE FAILED.
- 14.2.3 DO NOT CHARGE STATIC ELECTRICITY, AS THE CIRCUIT OF THIS MODULE CONTAINS CMOS LSIS. A WORKMAN'S BODY SHOULD ALWAYS BE STATIC-PROTECTED BY USE OF AN ESD STRAP. WORKING CLOTHES FOR SUCH PERSONNEL SHOULD BE OF STATIC-PROTECTED MATERIAL.
- 14.2.4 ALWAYS GROUND THE ELECTRICALLY-POWERED DRIVER BEFORE USING IT TO INSTALL THE LCD MODULE. WHILE CLEANING THE WORK STATION BY VACUUM CLEANER, DO NOT BRING THE SUCKING MOUTH NEAR THE MODULE ; STATIC ELECTRICITY OF THE ELECTRICALLY-POWERED DRIVER OR THE VACUUM CLEANER MAY DESTROY THE MODULE.
- 14.2.5 DON'T GIVE EXTERNAL SHOCK.
- 14.2.6 DON'T APPLY EXCESSIVE FORCE ON THE SURFACE.
- 14.2.7 LIQUID IN LCD IS HAZARDOUS SUBSTANCE. MUST NOT LICK AND SWALLOW.
WHEN THE LIQUID IS ATTACH TO YOUR, SKIN, CLOTH ETC. WASH IT OUT THOROUGHLY AND IMMEDIATELY.
- 14.2.8 DON'T OPERATE IT ABOVE THE ABSOLUTE MAXIMUM RATING.
- 14.2.9 STORAGE IN A CLEAN ENVIRONMENT, FREE FROM DUST, ACTIVE GAS, AND SOLVENT.
- 14.2.10 STORE WITHOUT ANY PHYSICAL LOAD.
- 14.2.11 REWIRING: NO MORE THAN 3 TIMES.