

TEP-0700-IMX7



- The TEP-0700-IMX7 is a low-power consumption HMI based on an NXP i.MX7 Dual core Cortex-A7™ + M4™ processor.
- The TEP-0700-IMX7 features a 7-inch widescreen ratio multitouch PCAP touch screen with LED backlight and brushed aluminum front bezel.
- Edge-computing ready with internal mini-PCIe expansion + SIM card slot for LTE/5G cloud connectivity.
- 2 RS-232, 2 CAN, 8 GPIO, 2 Gigabit Ethernet and USB interfaces.
- Orderable with single voltage 12VDC, wide voltage 9 - 36VDC or 802.3at PoE (power over ethernet) options.
- Linux, Yocto, Android runtime images and full source code available.

Specifications



Core System

Processor	NXP i.MX7 Dual
Architecture	ARM Cortex-A7 + M4
PMIC	NXP PF3000
Memory	Up to 2GB DDR3L
Storage	eMMC (4GB Default)

Connectivity

Network LAN	2x Atheros AR8035 Gigabit LAN
Power over Ethernet	PoE function 802.3at (optional)

Expansion Interfaces

Expansion Slots	1x M.2 slot for 3G/LTE module
-----------------	-------------------------------

External Connectors

Network	2x RJ45
USB	1x USB 2.0 Host 1x USB 2.0 OTG (Type-C)
CAN Bus	2x Flex CAN version 2.0B compliant
Serial	2x RS-232
GPIO	8x GPIO
Buttons	1x Boot Select 1x Reset
Indicators	1x Programmable LED
SIM Cardslot	1x Nano-SIM Card slot
SD Cardslot	1x MicroSD Card slot

Display

LCD	7 inch widescreen LCD with LED backlight
Resolution	800 x 480 pixels
Luminance	350 cd/m ²
Maximum Colors	16.7 million
Touchscreen	Projective Capacitive (multitouch)

Power Specifications

Power Input	Available with 12V 9-36V (wide power input)
Power Over Ethernet	PoE function 802.3at (optional)
Power Connector	2-pin Micro-Fit 3.0
Power Consumption	Depending on Configuration

Operation Systems

Standard Support	Linux Yocto Android
Extended Support	Commercial Linux

Dimensions (units in mm)

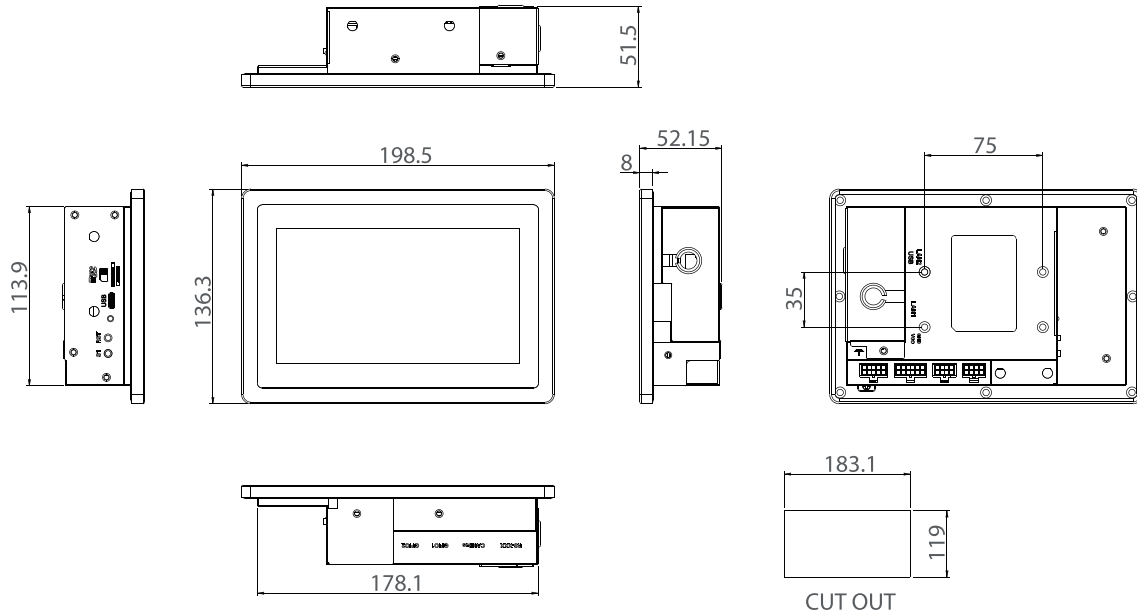

Environmental and Mechanical

Enclosure Material	Metal
Front Bezel	Brushed Anodized Aluminium
IP Rating	IP65 Front
Dimensions	198 (W) x 136 (H) x 52 (D) mm
Weight	945 grams
Temperature	Commercial: 0° to +50°C
Relative Humidity	10 to 90 %
MTBF	50 000 Hours
Shock	15G half-sine 11 ms duration
Vibration	1 Grms random 5-500Hz hr/axis
Certification	Compliant with CE / FCC / RoHS / REACH directives

Modular Expansion Options

Power Expansion Module	TXR-P1-12V-LAN1 (12V 3A) TXR-P1-1030V-LAN1 (9-36V 5A) TXR-P1-12V-POE1 (12V 3A) or (PoE 802.3at)
------------------------	--

Mounting Options

VESA Mounting	35*75 VESA MIS C. Standard (separate purchase)
Surface Mounting	8 mounting holes

Order Information

TEP0700-IMX7x-Rxx-Exx-Lxxx-xxxx-xxxx

	Code	Description
Processor	IMX7D	NXP i.MX7 Dual
Processor Speed	R05	512MB DDR3L
Memory	R10	1GB DDR3L
Memory	R20	2GB DDR3L
Storage	E04	eMMC capacity E04 = 4GB / E16 = 16GB / E32 = 32GB / E64 = 64GB
Power Expansion	L112	TXB-P1-12V-LAN1 (12V 3A)
	L130	TXB-P1-1030V-LAN1 (9-36V 5A)
	LPOE	TXB-P1-12V-POE1 (12V 3A) or (PoE 802.3at)
Custom ID	XXXX	Custom Part number ID for customized Software loader and special component (BOM)